



PL	INSTRUKCJA MONTAŻU	Nazwa	Karuzela Verto	Nr kat.	57101MA2
ENG	ASSEMBLY INSTRUCTIONS	Product		Cat. no.	
DEU	MONTAGEANLEITUNG	Name		Art.-Nr.	
FRA	INSTRUCTIONS D'INSTALLATION	Catégorie		Référence	

57101MA2



Wiek użytkowników Age of users Altersgruppe	Ilość użytkowników Number of users Anzahl der Benutzer Nombre d'utilisateurs	Przeznaczenie urządzenia Purpose of device Bestimmung des Spielgerätes	Zgodność z normą In accordance with the standard Geltende Norm
3-14	1	do zabawy na zewnątrz for outdoor playing zum draußen Spielen	PN-EN 1176-1:2017 PN-EN 1176-5:2020
NOVUM Sp. z o.o. Sp. k. ul. Bolesława Chrobrego 1, 12-100 Szczytno		e-mail: biuro@novumedukacja.pl	www.novumedukacja.pl
NOVUM Sp. z o.o. Sp. k. ul. Bolesława Chrobrego 1, 12-100 Szczytno		e-mail: eksport@novumgrom.com	www.novum4kids.com
-	-	-	-
-	-	-	-

UWAGA / WARNING / ACHTUNG / ATTENTION:

PL Jeżeli w zestawie występuje zjeżdżalnia, zestaw należy posadowić w taki sposób, aby ślizg zjeżdżalni znajdował się od strony północnej, czyli od strony nienasłonecznionej, aby zapobiegać nadmiernemu nagrzewaniu się ślizgu.

ENG If there is a slide in the set, it should be installed from the north, poorly sunny side to avoid possible hazards (burns) through direct skin contact.

DEU Wenn eine Spielplatzanlage eine Rutsche enthält, sollte diese Anlage so platziert werden, dass die Rutsche sich auf der Nordseite befindet, dh. auf der schattigen Seite, um übermäßige Erwärmung der Rutschbahn zu vermeiden.

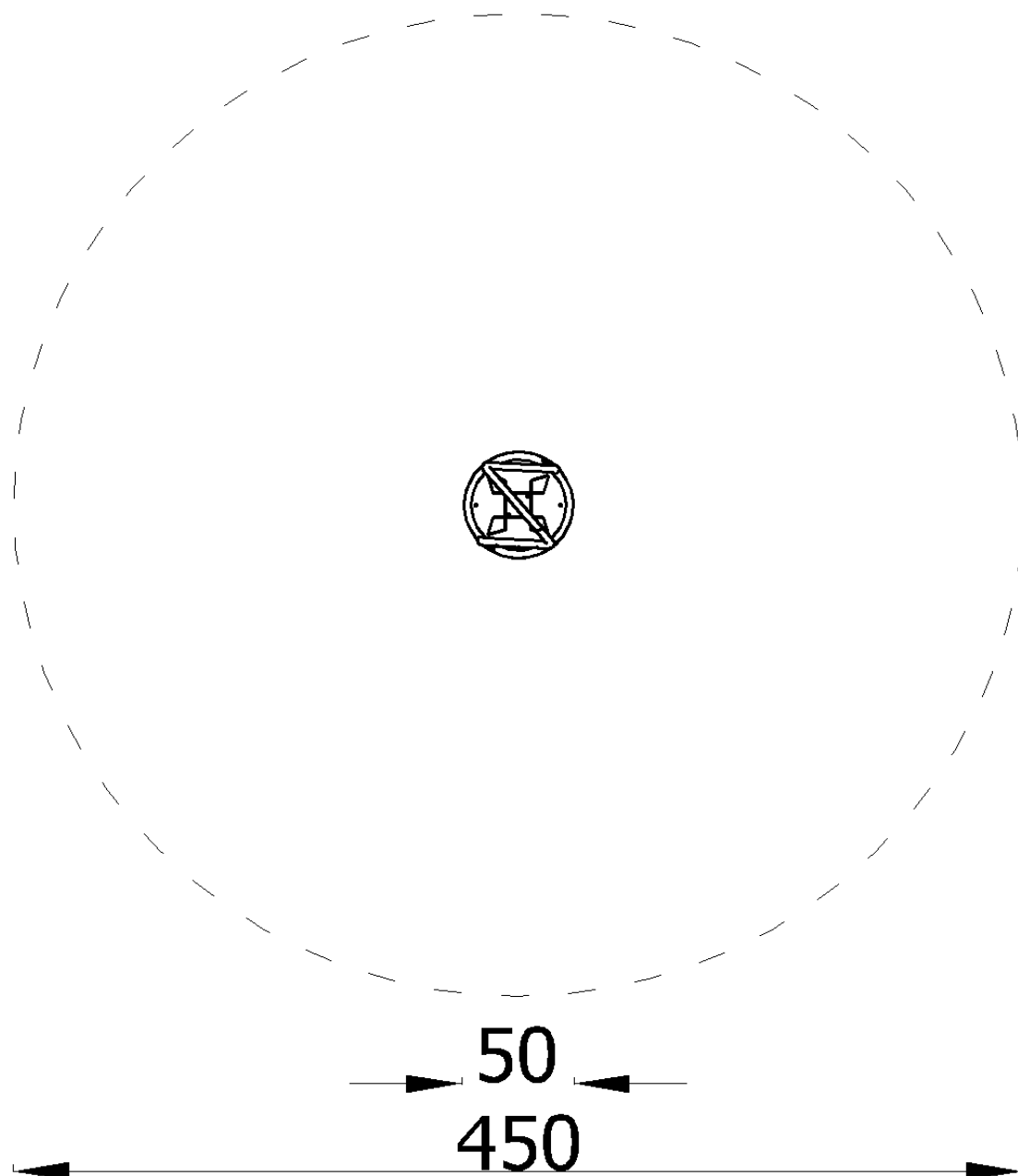

Montaż zgodnie z planem zagospodarowania terenu.
 Installation in accordance with the land development plan.
 Montage gemäß dem Flächennutzungsplan

Bezpieczna nawierzchnia / Safe surface / Safe Oberfläche / Surface sûre

Strefa Zone Zone Zone	Max. wysokość upadku Max. fall height Max. Fallhöhe Max. hauteur de chute	Pole powierzchni Surface area Fläche Surface	Obwód strefy bezpiecz. Perimeter security zone Umkreis der Fallschutzfläche Zone de périmètre de sé.
A	1,00 m	16,00 m ²	14,00 m
B	-	-	
C	-	-	

Nawierzchnia / Safe surface / Fallschutzbelag / fr			57101MA2
	Material Material Material	Min. wysokość warstwy Min. layer thicknesses Min. Schichtöhe	
$h \leq 0,6$ m	Beton / Concrete / Beton Nawierzchnia bitumiczna / Bituminous surfacing / Bituminöse Oberfläche		
$h \leq 1$ m	Gleba / Topsoil / Boden Darń / Turf / Grasnarbe		
$h \leq 2$ m	Kora / Bark / Borke	20÷80 mm	300
	Wióry / Wood chips / Holz hackschnitzel	5÷30 mm	
	Piasek / Sand / Sand Żwir / Gravel / Kies	0,25÷8 mm	
$h \leq 3$ m	Kora / Bark / Borke	20÷80 mm	400
	Wióry / Wood chips / Holz hackschnitzel	5÷30 mm	
	Piasek / Sand / Sand Żwir / Gravel / Kies	0,25÷8 mm	
$h \leq 3$ m	Nawierzchnia syntetyczna / Synthetic granulates / Synthetische Oberfläche	wg danych producenta acc. to the manufacturer's data nach Angaben des Herstellers	

Posadowienie / Foundation / Gründung / Fondation	57101MA2
--	----------

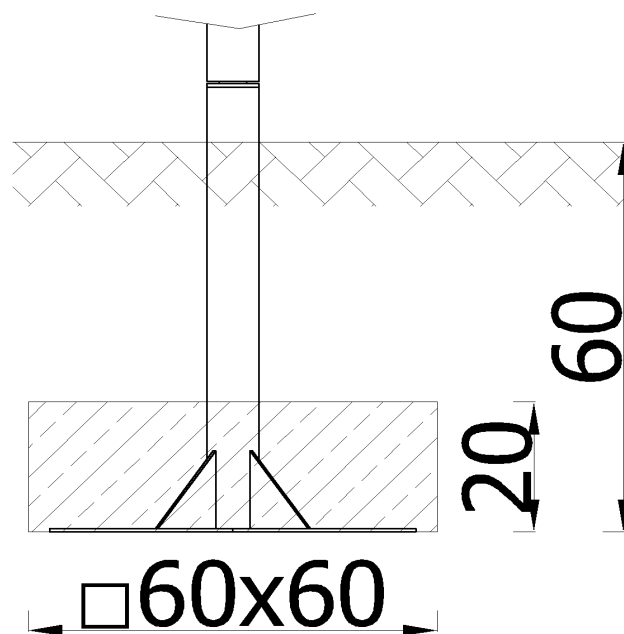

Beton / Concrete / Beton: **C16/20** - **0,07** m³

W celu kontroli fundamentów należy usunąć nawierzchnię bezpieczną / piasek / żwir etc.
In order to control the foundations, remove the safe surface (sand, gravel, etc.)
Um die Fundamente zu überprüfen, entfernen Sie den Fallschutzbelag: Sand/ Kies etc.

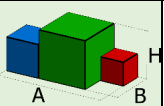
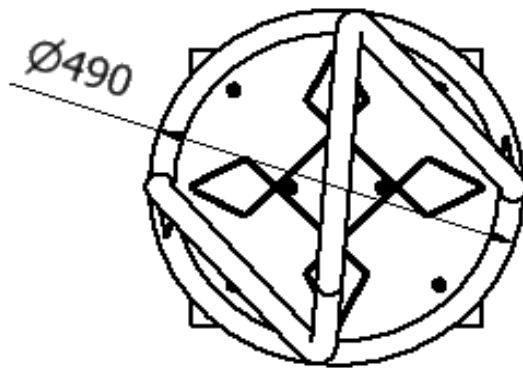
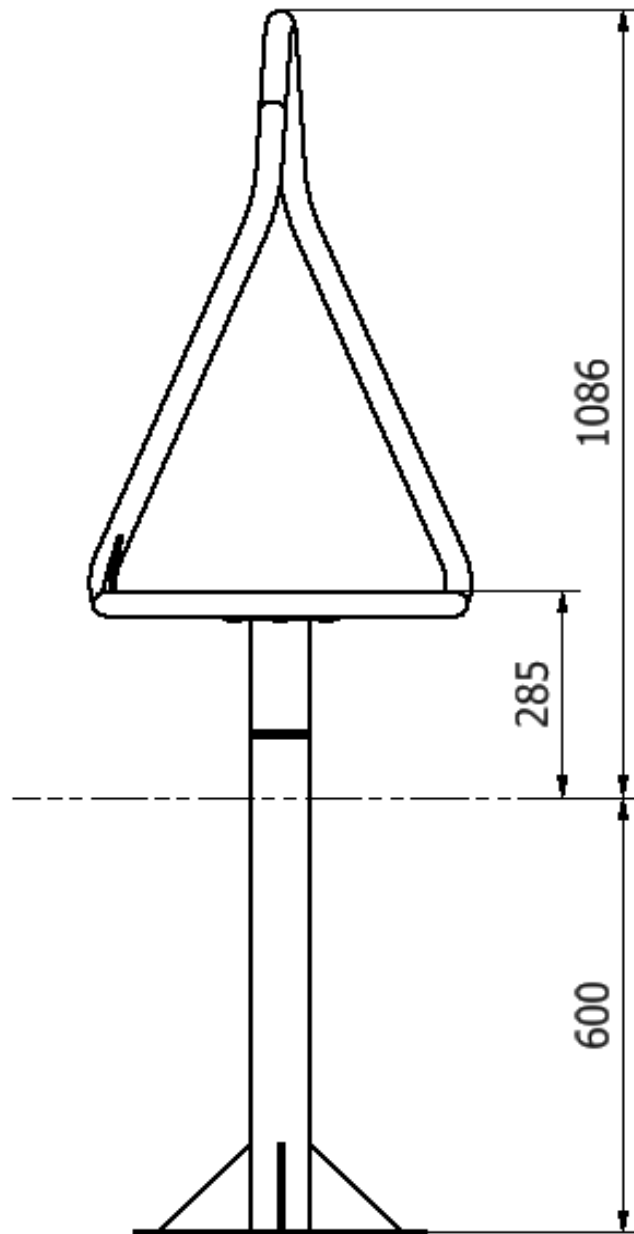

0,5x0,5x1,08
(AxBxH) [m]

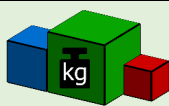

26 kg

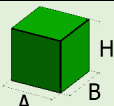

0,5x0,5x1,68
(AxBxH) [m]



26 kg

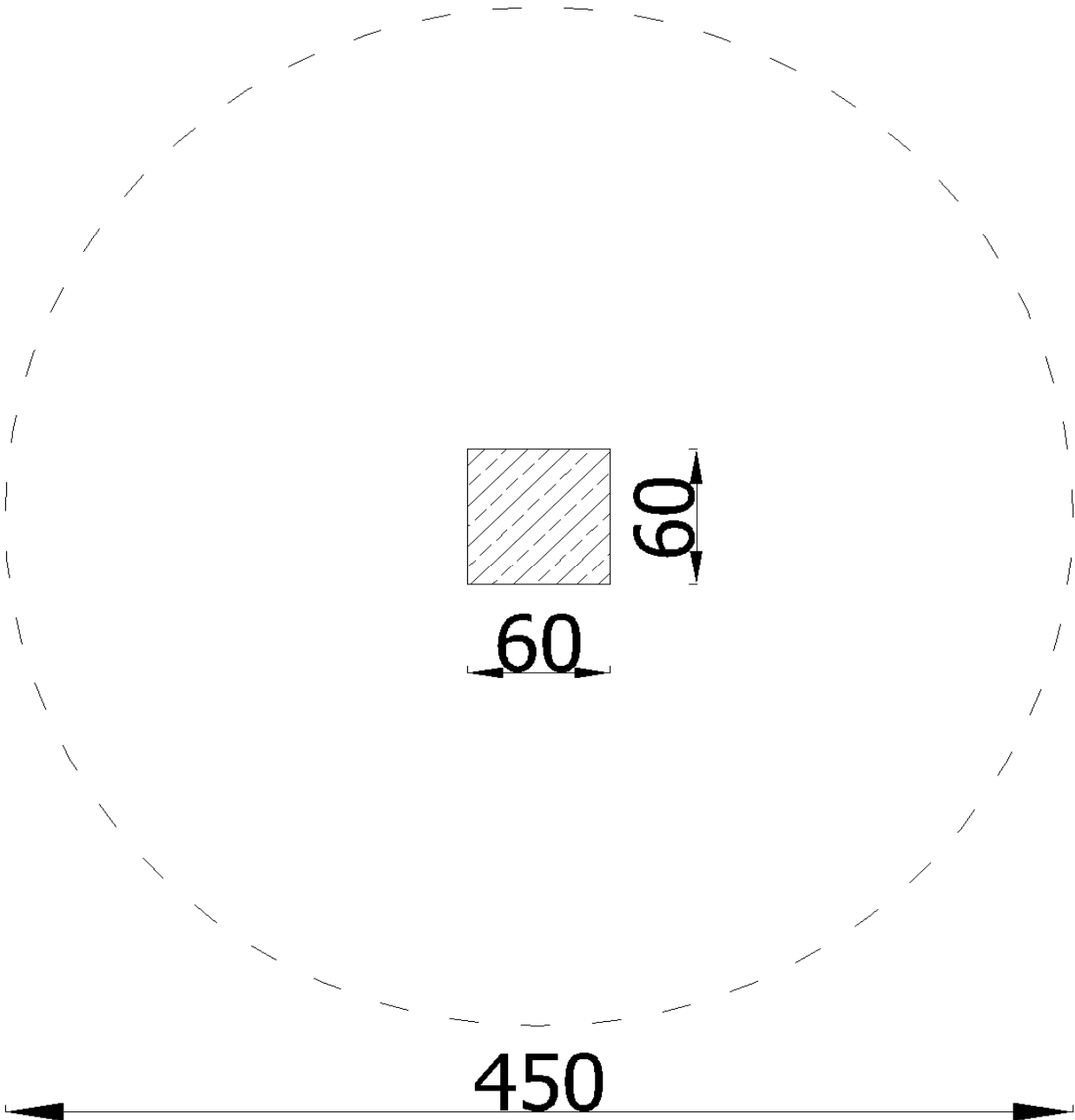

Narzędzia / Tools / Handwerkzeug / Outils

57101MA2

															
								5 m	30 m						
															
2,5 m				60 cm	100 cm										
															
				7 mm								13 mm	17 mm	19 mm	24 mm
															
13 mm	17 mm	19 mm	24 mm	4 mm	5 mm	6 mm	8 mm	T40				T45			
															