



PL	INSTRUKCJA MONTAŻU	Nazwa	Zjeżdżalnia na nasypie 120 cm	Nr kat.	21151
ENG	ASSEMBLY INSTRUCTIONS	Product	Slide for Embankment 120 cm	Cat. no.	
DEU	MONTAGEANLEITUNG	Name	Hanggrutsche, Höhe 120 cm	Art.-Nr.	

21151



Wiek użytkowników Age of users Altersgruppe	Ilość użytkowników Number of users Anzahl der Benutzer	Przeznaczenie urządzenia Purpose of device Bestimmung des Spielgerätes	Zgodność z normą In accordance with the standard Geltende Norm
3-14	1	do zabawy na zewnątrz for outdoor playing zum draußen Spielen	PN-EN 1176-1+A1:2024-03
NOVUM Sp. z o.o. ul. Gnieźnieńska 2a, 12-100 Szczytno		e-mail: kontakt@novum4kids.pl e-mail: export@novum4kids.com	www.novum4kids.pl www.novum4kids.com

UWAGA / WARNING / ACHTUNG:

PL Jeżeli w zestawie występuje zjeżdżalnia, zestaw należy posadzić w taki sposób, aby ślizg zjeżdżałni znajdował się od strony północnej, czyli od strony nienasłonecznionej, aby zapobiegać nadmiernemu nagrzewaniu się ślizgu.

ENG If there is a slide in the set, it should be installed from the north, poorly sunny side to avoid possible hazards (burns) through direct skin contact.

DEU Wenn eine Spielplatzanlage eine Rutsche enthält, sollte diese Anlage so platziert werden, dass die Rutsche sich auf der Nordseite befindet, dh. auf der schattigen Seite, um übermäßige Erwärmung der Rutschbahn zu vermeiden.

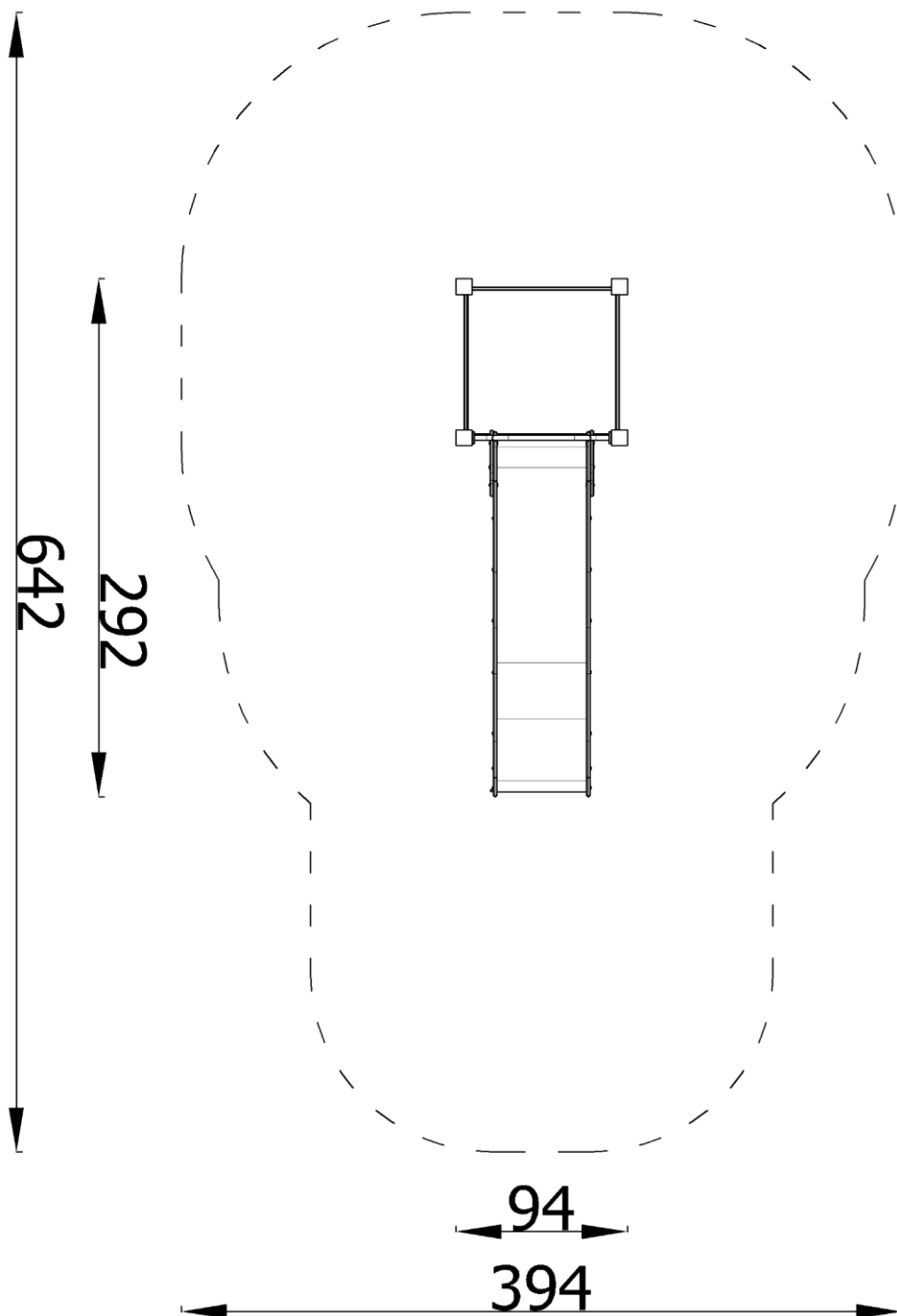

Montaż zgodnie z planem zagospodarowania terenu.
 Installation in accordance with the land development plan.
 Montage gemäß dem Flächennutzungsplan

Bezpieczna nawierzchnia / Safe surface / Safe Oberfläche

Strefa Zone Zone	Max. wysokość upadku Max. fall height Max. Fallhöhe	Pole powierzchni Surface area Fläche	Obwód strefy bezpiecz. Perimeter security zone Umkreis der Fallschutzfläche
A	1,00 m	20,50 m ²	17,50 m
B	-	-	
C	-	-	

Nawierzchnia / Safe surface / Fallschutzbelag

21151



Materiał
Material
Material

Min. wysokość warstwy
Min. layer thicknesses
Min. Schichtöhe

$h < 0,6$ m

Beton / Concrete / Beton
Nawierzchnia bitumiczna / Bituminous surfacing / Bituminöse Oberfläche

$h \leq 1$ m

Gleba / Topsoil / Boden
Darıń / Turf / Grasnarbe

$h \leq 2$ m

Kora / Bark / Borke

20÷80 mm

Wióry / Wood chips / Holzhackschnitzel

5÷30 mm

Piasek / Sand / Sand

0,25÷8 mm

Żwir / Gravel / Kies

2÷8 mm

300

$h \leq 3$ m

Kora / Bark / Borke

20÷80 mm

Wióry / Wood chips / Holzhackschnitzel

5÷30 mm

Piasek / Sand / Sand

0,25÷8 mm

Żwir / Gravel / Kies

400

$h \leq 3$ m

Nawierzchnia syntetyczna / Synthetic granulates / Synthetische Oberfläche

wg danych producenta
acc. to the manufacturer's data
nach Angaben des Herstellers

Posadowienie / Foundation / Gründung

21151

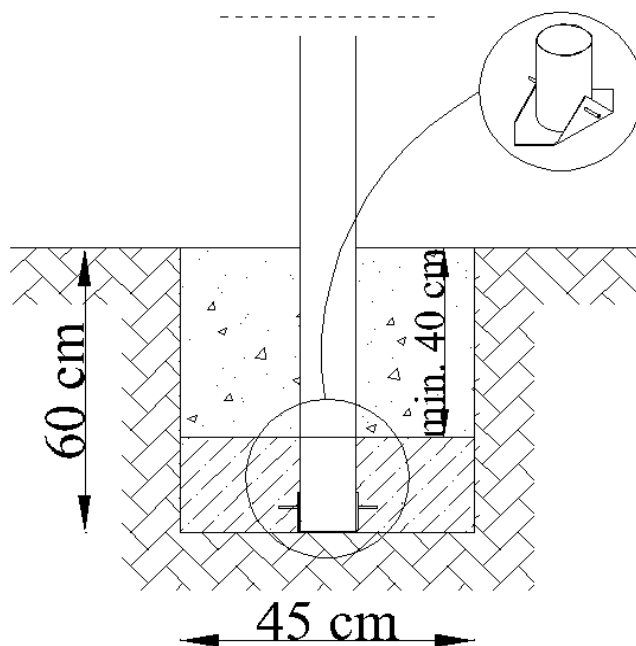

Beton / Concrete / Beton: **C16/20** - **0,19** m³

W celu kontroli fundamentów należy usunąć nawierzchnię bezpieczną / piasek / żwir etc.
In order to control the foundations, remove the safe surface (sand, gravel, etc.)
Um die Fundamente zu überprüfen, entfernen Sie den Fallschutzbelag: Sand/ Kies etc.

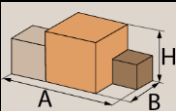
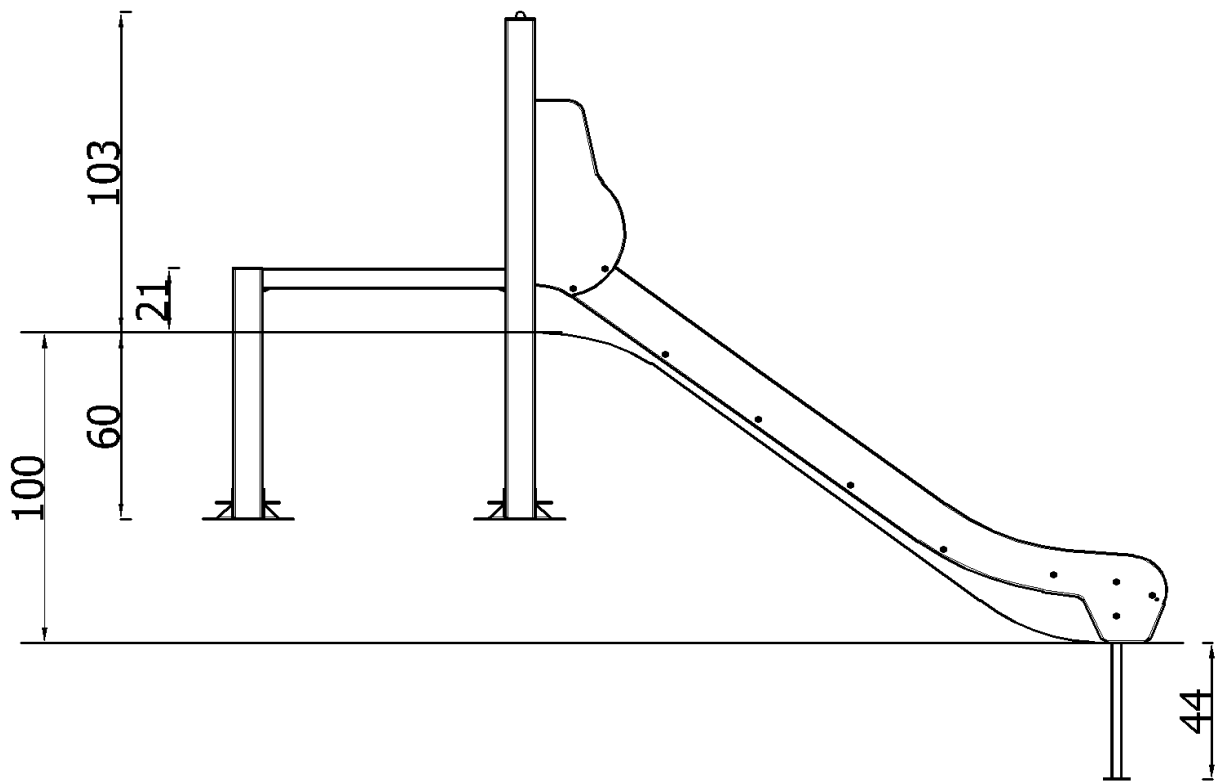

2,92 x 0,94 x
1,03
(AxBxH) [m]



106 kg

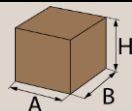

2,47 x 2,07 x
0,76
(AxBxH) [m]



49 kg

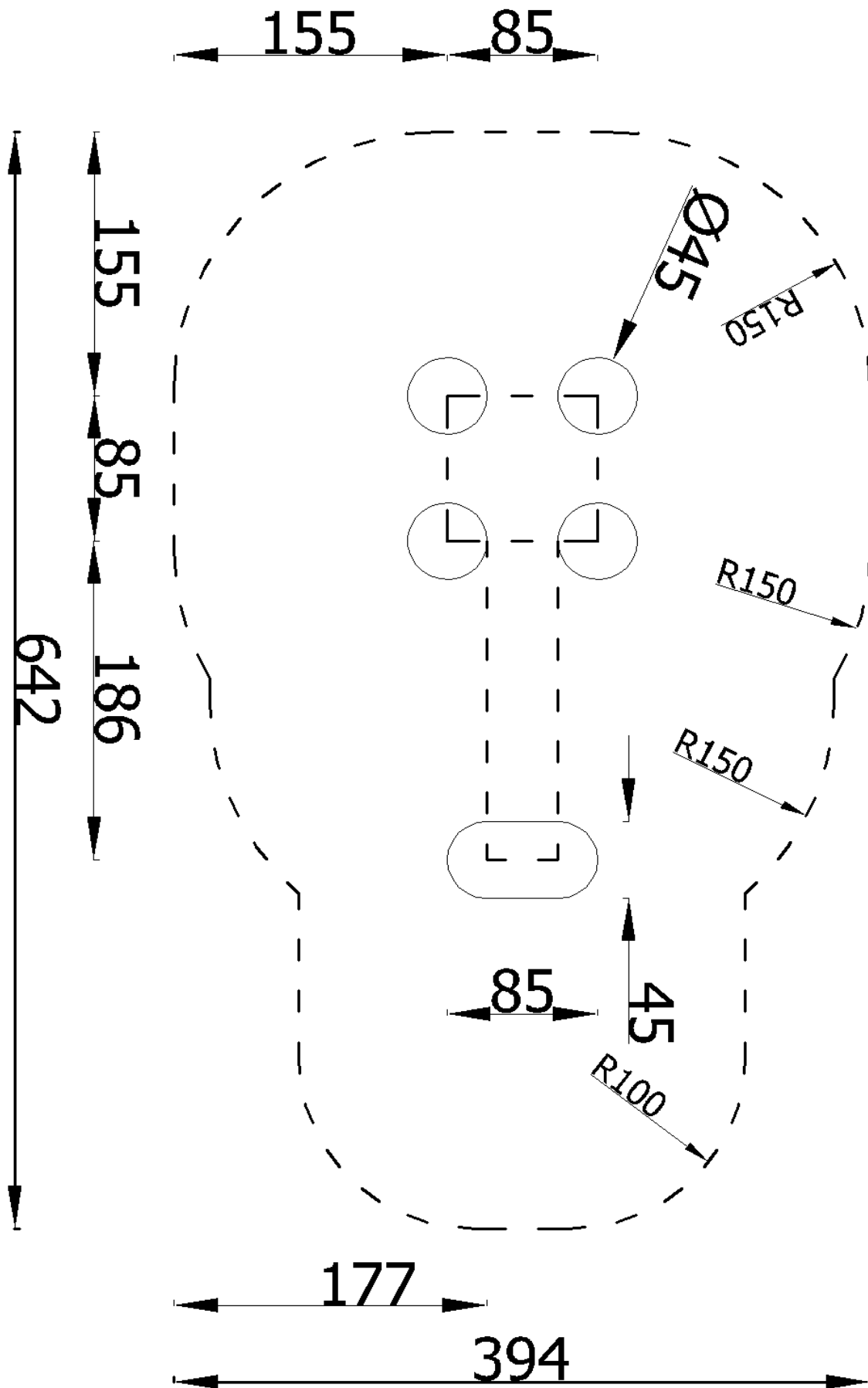

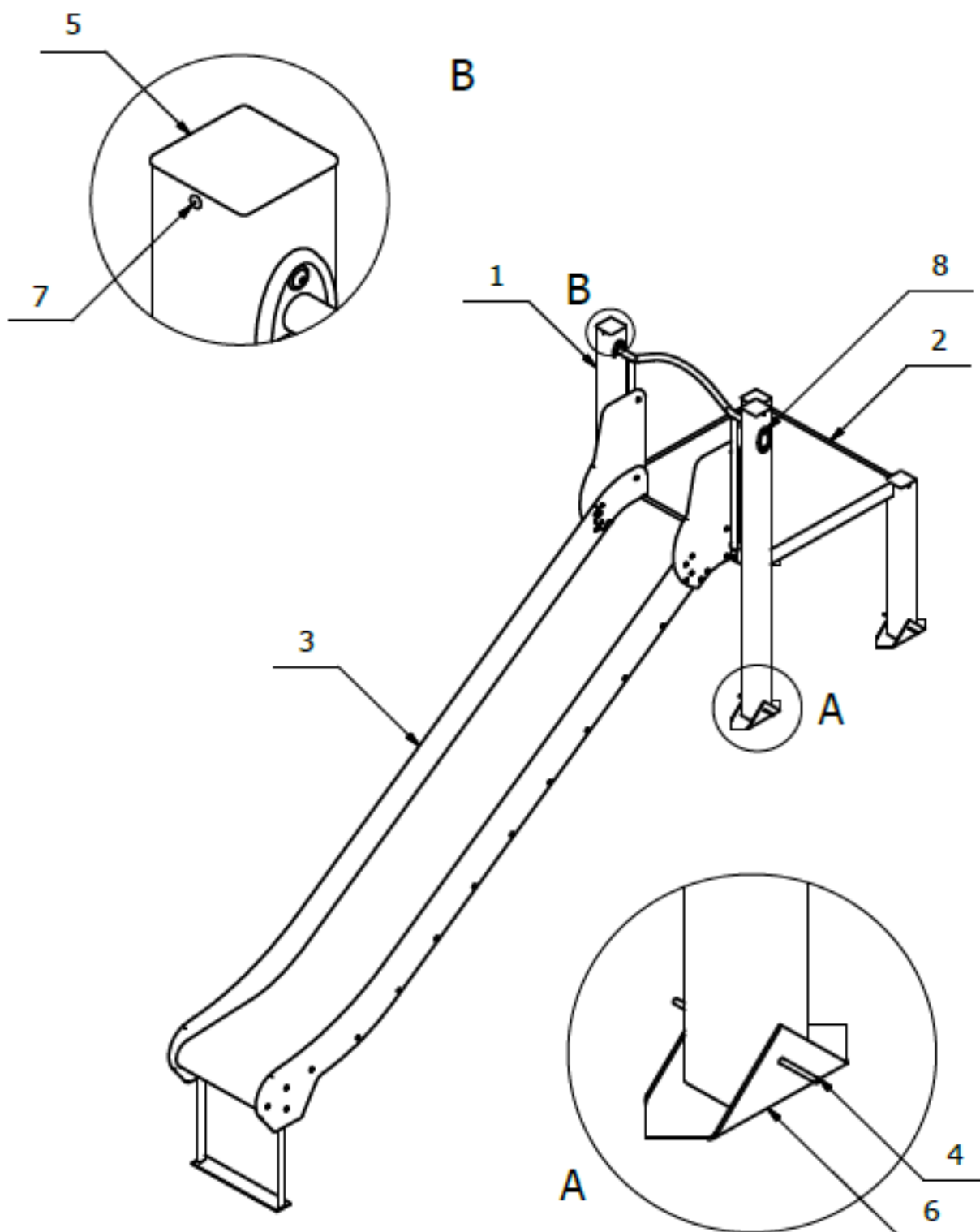









Części zamienne dostępne u producenta.
Stosować klej do gwintów w połączeniach śrubowych.

Spare parts available from the manufacturer.
Use thread glue in screw connections.

Ersatzteile beim Hersteller erhältlich.
Gewindekleber für Schraubverbindungen verwenden.

8	8918_QM	1
7	DIN7337_A5x10_AL	4
6	B_8802_027	2
5	8912_212	2
4	8850_002	2
3	2113_QM	1
2	2071_QM	1
1	21151_1_4_MP	1
Lp. No.	Nr części Part No.	Ilość Quantity
Art. Nr.	Teile-Nr	Anzahl

															
								5 m	30 m						
															
2,5 m				60 cm	100 cm										
															
				7 mm								13 mm	17 mm	19 mm	24 mm
															
13 mm	17 mm	19 mm	24 mm	4 mm	5 mm	6 mm	8 mm	T40				T45			
															

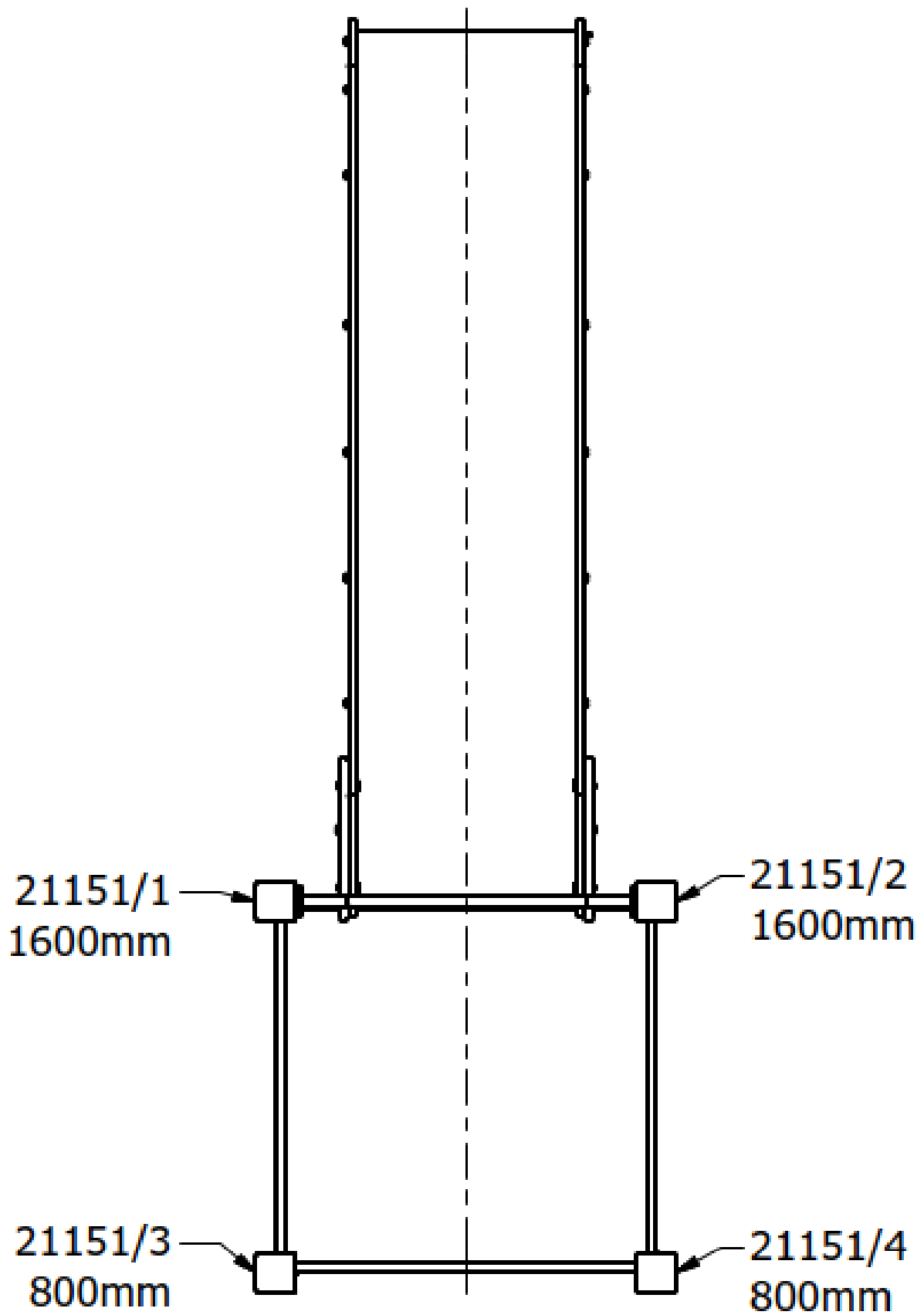

ISO7380_2_M8x16_A2	8
Drawing/Norm number	Quantity

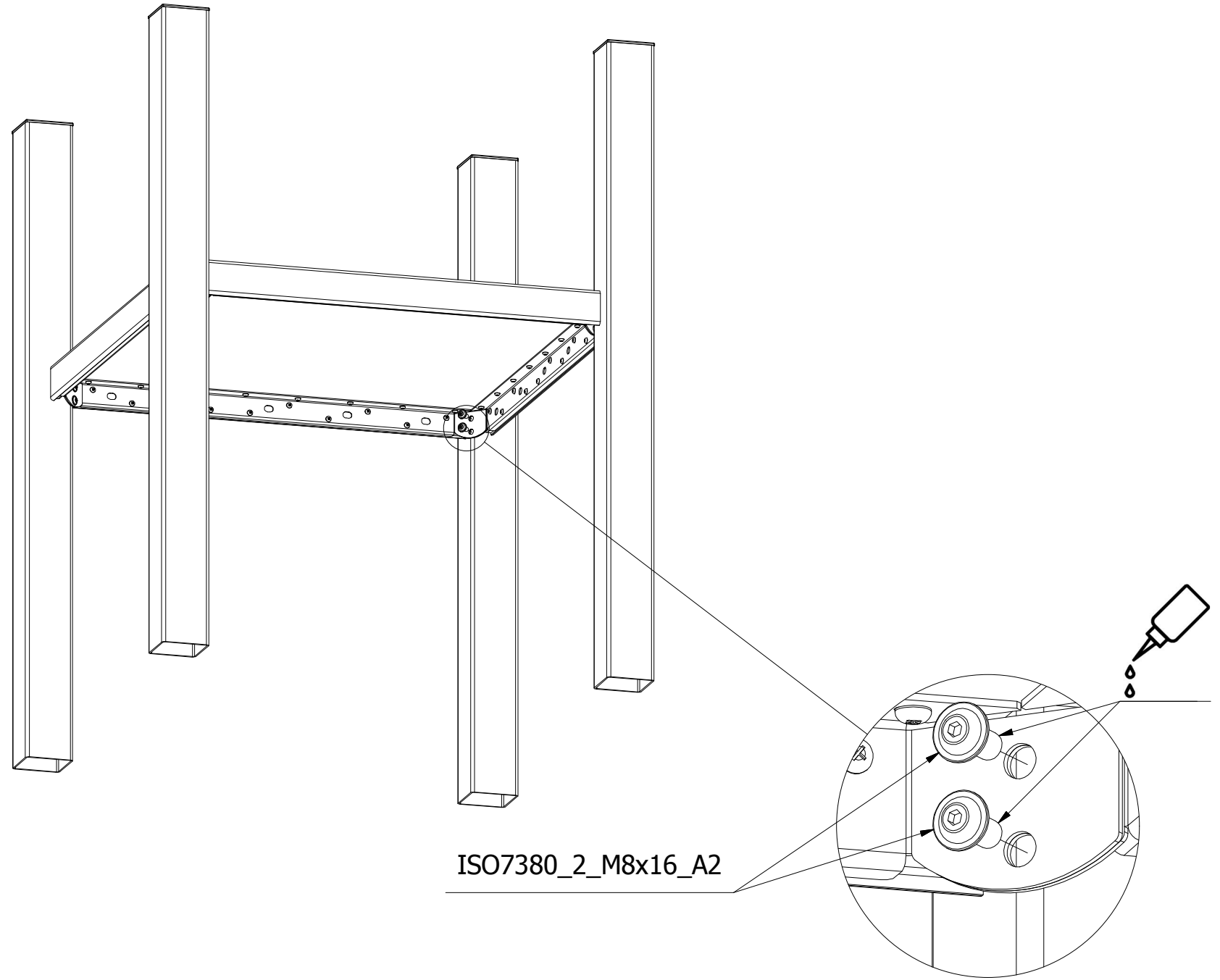
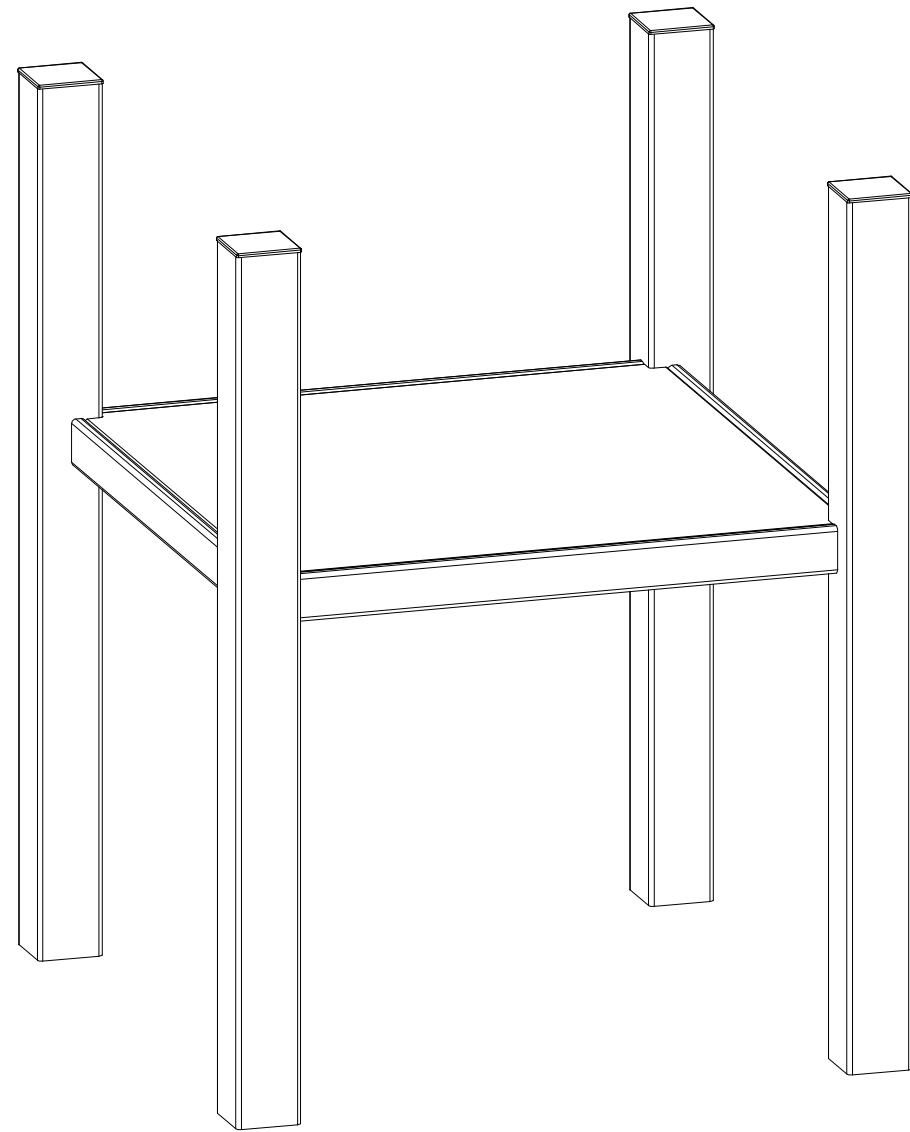

ISO7380_2_M8x16_A2

ISO7380_2_M8x16_A2	2
DIN986_M8_A2	4
ISO7380_2_M8x40_A2	2
ISO7380_2_M8x35_A2	2
ISO7089_8_A2	4
ISO7380_2_M8x30_A2	2
8919_002	2
Drawing/Norm number	Quantity

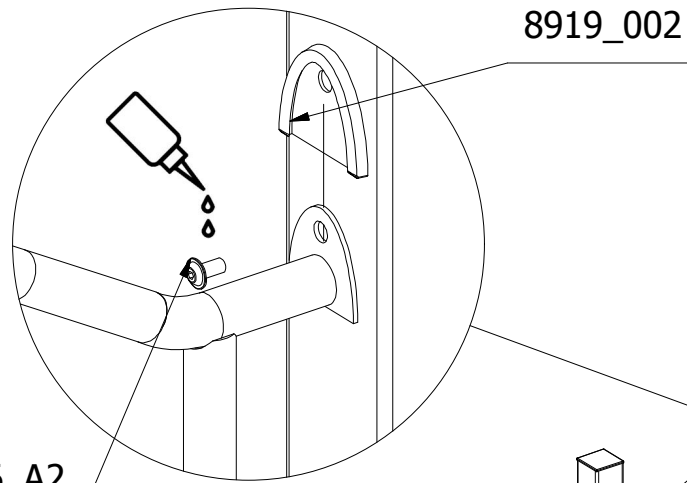

ISO7380_2_M8x16_A2

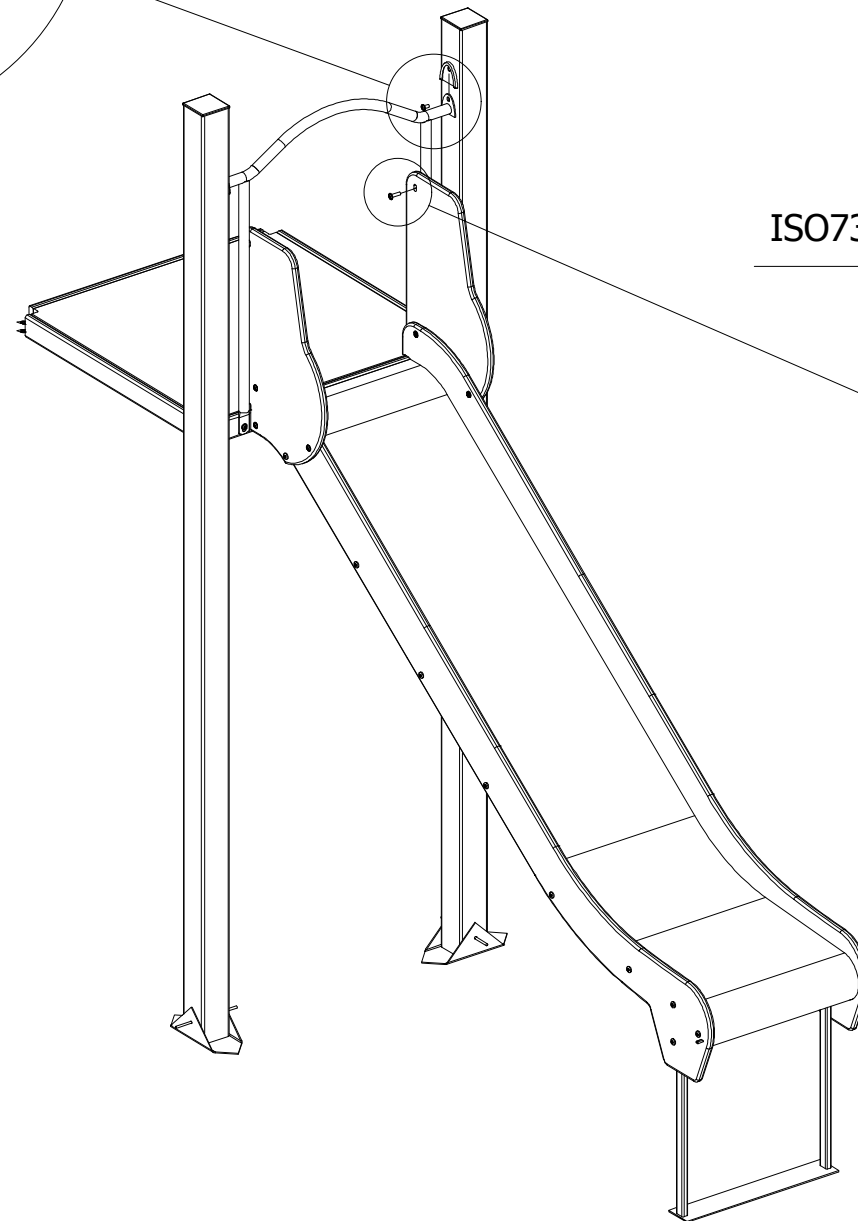
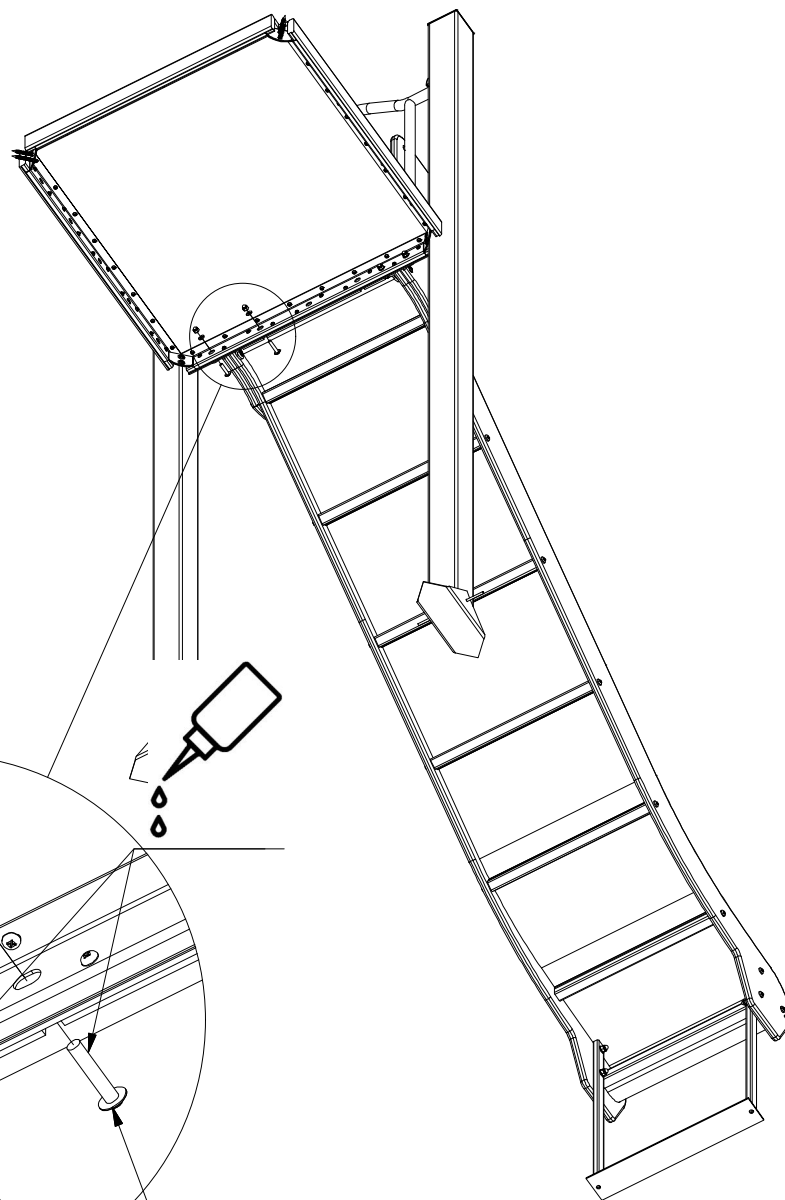

ISO7380_2_M8x30_A2

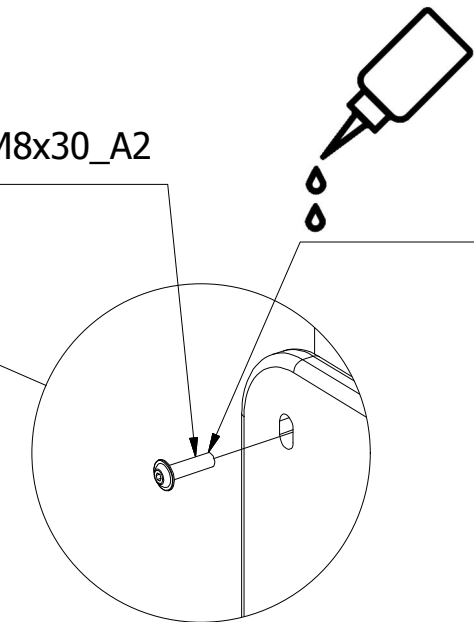

DIN986_M8_A2

ISO7089_8_A2

DIN986_M8_A2

ISO7089_8_A2

ISO7380_2_M8x35_A2

ISO7380_2_M8x40_A2