

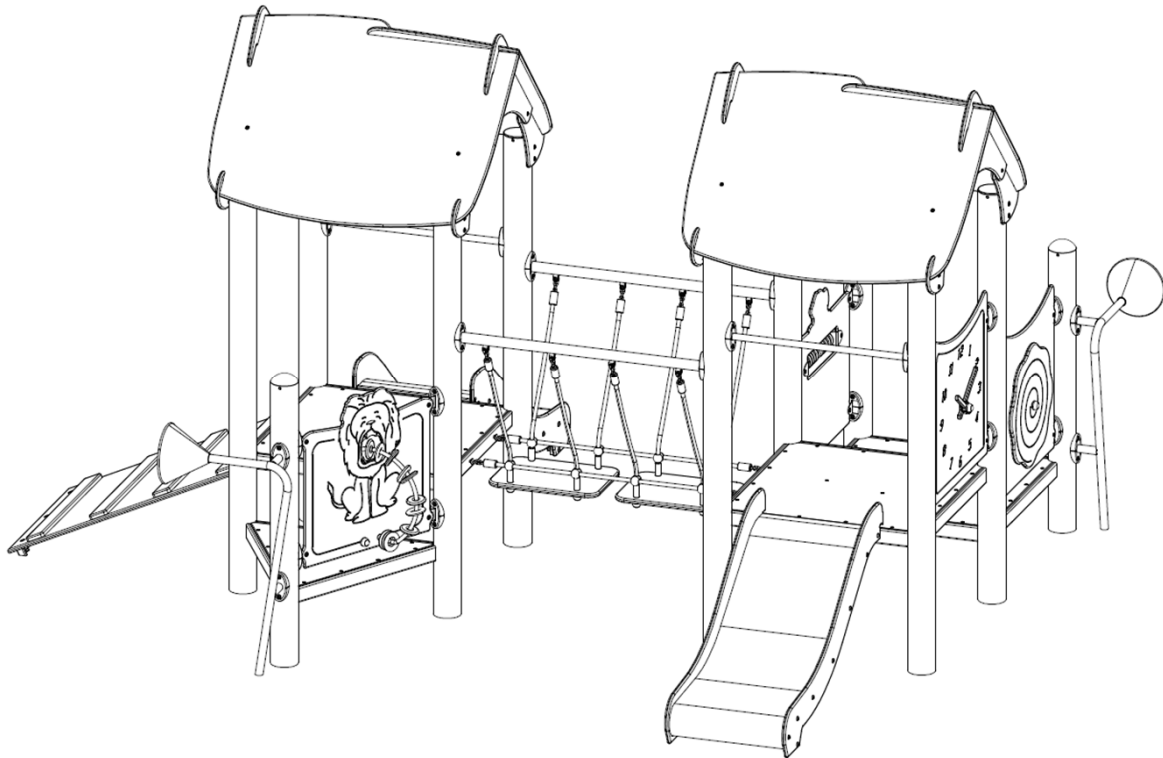

|     |                       |         |                               |          |       |
|-----|-----------------------|---------|-------------------------------|----------|-------|
| PL  | INSTRUKCJA MONTAŻU    | Nazwa   | Zestaw Orbis 11652            | Nr kat.  | 11652 |
| ENG | ASSEMBLY INSTRUCTIONS | Product | Orbis 11652                   | Cat. no. |       |
| DEU | MONTAGEANLEITUNG      | Name    | Orbis 11652 / Metall- Pfosten | Art.-Nr. |       |

## 11652



| Wiek użytkowników<br>Age of users<br>Altersgruppe     | Ilość użytkowników<br>Number of users<br>Anzahl der Benutzer | Przeznaczenie urządzenia<br>Purpose of device<br>Bestimmung des Spielgerätes | Zgodność z normą<br>In accordance with the standard<br>Geltende Norm |
|---|--|--|--|
| 1-14  | 10   | do zabawy na zewnątrz<br>for outdoor playing<br>zum draußen Spielen          | PN-EN 1176-1:2017  |
| NOVUM Sp. z o.o. ul. Gnieźnieńska 2a, 12-100 Szczytno |  | e-mail: kontakt@novum4kids.pl<br>e-mail: export@novum4kids.com               | www.novum4kids.pl<br>www.novum4kids.com                              |

**UWAGA / WARNING / ACHTUNG:**

**PL** Jeżeli w zestawie występuje zjeżdżalnia, zestaw należy posadzić w taki sposób, aby ślizg zjeżdżałni znajdował się od strony północnej, czyli od strony nienasłonecznionej, aby zapobiegać nadmiernemu nagrzewaniu się ślizgu.

**ENG** If there is a slide in the set, it should be installed from the north, poorly sunny side to avoid possible hazards (burns) through direct skin contact.

**DEU** Wenn eine Spielplatzanlage eine Rutsche enthält, sollte diese Anlage so platziert werden, dass die Rutsche sich auf der Nordseite befindet, dh. auf der schattigen Seite, um übermäßige Erwärmung der Rutschbahn zu vermeiden.

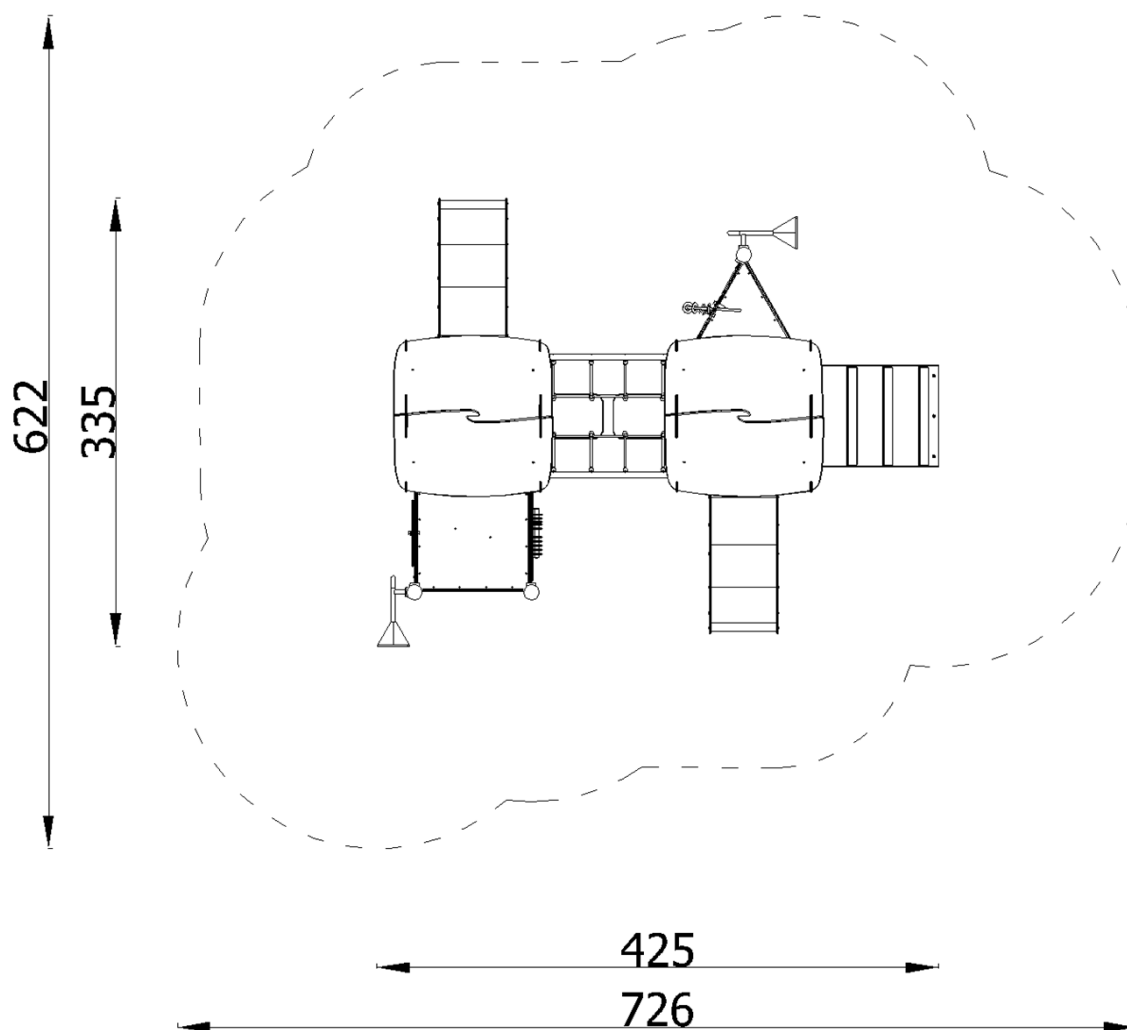

Montaż zgodnie z planem zagospodarowania terenu.  
 Installation in accordance with the land development plan.  
 Montage gemäß dem Flächennutzungsplan

Bezpieczna nawierzchnia / Safe surface / Safe Oberfläche

| Strefa<br>Zone<br>Zone | Max. wysokość upadku<br>Max. fall height<br>Max. Fallhöhe | Pole powierzchni<br>Surface area<br>Fläche | Obwód strefy bezpiecz.<br>Perimeter security zone<br>Umkreis der Fallschutzfläche |
|------------------------|---|--|---|
| A                      | 1,00 m  | 34,50 m <sup>2</sup>                       | 22,00 m   |
| B                      | -   | -  |   |
| C                      | -   | -  |   |

| Nawierzchnia / Safe surface / Fallschutzbelag                                     |  |   | 11652 |
|---|--|---|-------|
|  | Materiał<br>Material<br>Material   | Min. wysokość warstwy<br>Min. layer thicknesses<br>Min. Schichtöhe                      |       |
| $h < 0,6$ m   | Beton / Concrete / Beton<br>Nawierzchnia bitumiczna / Bituminous surfacing / Bituminöse Oberfläche |   |       |
| $h \leq 1$ m  | Gleba / Topsoil / Boden<br>Darrí / Turf / Grasnarbe  |   |       |
| $h \leq 2$ m  | Kora / Bark / Borke  | 20÷80 mm  | 300   |
|   | Wióry / Wood chips / Holzhackschnitzel   | 5÷30 mm   |       |
|   | Piasek / Sand / Sand<br>Żwir / Gravel / Kies   | 0,25÷8 mm   |       |
| $h \leq 3$ m  | Kora / Bark / Borke  | 20÷80 mm  | 400   |
|   | Wióry / Wood chips / Holzhackschnitzel   | 5÷30 mm   |       |
|   | Piasek / Sand / Sand<br>Żwir / Gravel / Kies   | 0,25÷8 mm   |       |
| $h \leq 3$ m  | Nawierzchnia syntetyczna / Synthetic granulates / Synthetische Oberfläche                          | wg danych producenta<br>acc. to the manufacturer's data<br>nach Angaben des Herstellers |       |

| Posadowienie / Foundation / Gründung | 11652 |
|--------------------------------------|-------|
|--------------------------------------|-------|

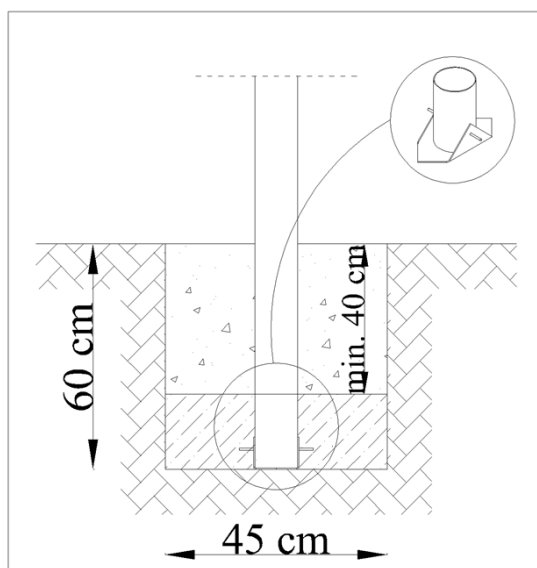

Beton / Concrete / Beton: **C16/20** - **0,80** m<sup>3</sup>

W celu kontroli fundamentów należy usunąć nawierzchnię bezpieczną / piasek / żwir etc.  
 In order to control the foundations, remove the safe surface (sand, gravel, etc.)  
 Um die Fundamente zu überprüfen, entfernen Sie den Fallschutzbelag: Sand/ Kies etc.

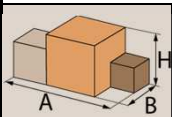
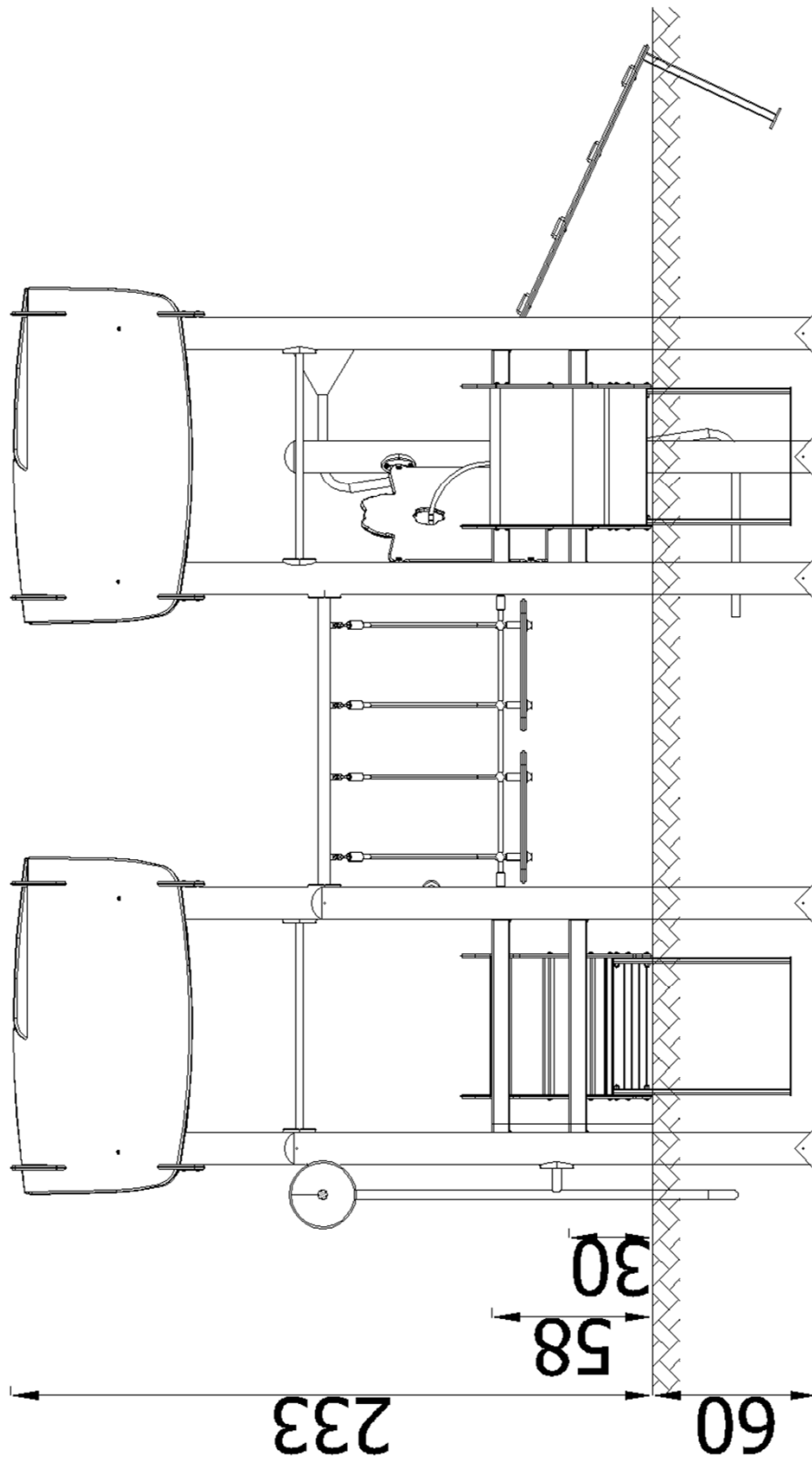

4,25x3,35x2,33  
(AxBxH) [m]



286 kg

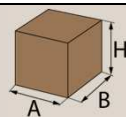

2,35x0,12x0,3  
(AxBxH) [m]



36 kg

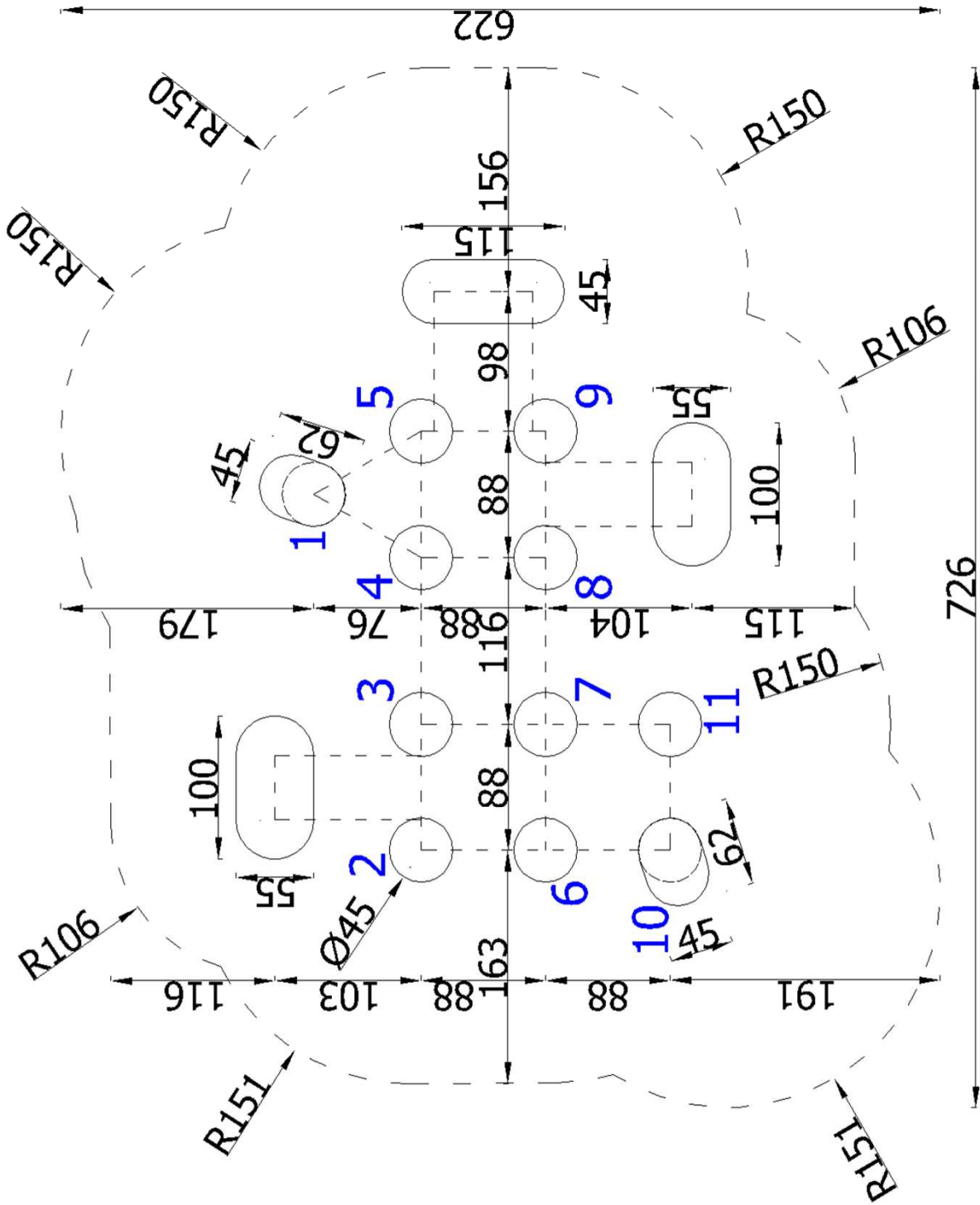

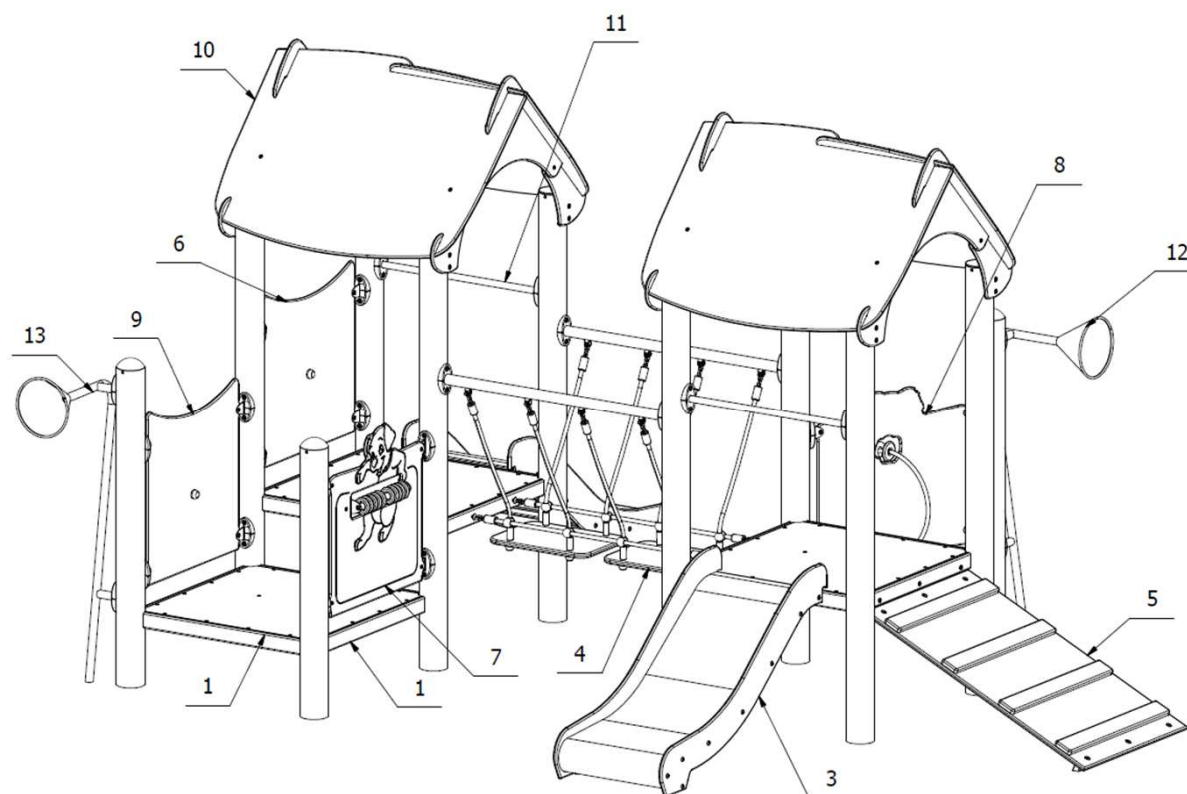

Części zamienne dostępne u producenta.  
Stosować klej do gwintów w połączeniach śrubowych.

Spare parts available from the manufacturer.  
Use thread glue in screw connections.

Ersatzteile beim Hersteller erhältlich.  
Gewindekleber für Schraubverbindungen verwenden.

|     |                    |                 |
|-----|--------------------|-----------------|
| 15  | 11652/1 - 11682/11 | 1               |
| 14  | R_11652_001        | 1               |
| 13  | 9048P_RM           | 1               |
| 12  | 9048L_RM           | 1               |
| 11  | 2604_RM            | 2               |
| 10  | 2515_RM            | 2               |
| 9   | 2440_RM            | 1               |
| 8   | 2439_RM            | 1               |
| 7   | 2437_RM            | 1               |
| 6   | 2409_RM            | 1               |
| 5   | 23124              | 1               |
| 4   | 2283_RM            | 1               |
| 3   | 2107               | 2               |
| 2   | 2072_RM            | 1               |
| 1   | 2070_RM            | 3               |
| Lp. | Nr części          | Ilość           |
| No. | Art. Nr.           | Quantity Anzahl |

Narzędzia / Tools / Handwerkzeug

11652

|   |       |       |       |   |        |      |      |  |      |  |  |   |       |       |       |
|---|-------|-------|-------|---|--------|------|------|--|------|--|--|---|-------|-------|-------|
|    |       |       |       |    |        |      |      |    |      |  |  |    |       |       |       |
|   |       |       |       |   |        |      |      | 5 m  | 30 m |  |  |   |       |       |       |
|    |       |       |       |    |        |      |      |    |      |  |  |    |       |       |       |
| 2,5 m   |       |       |       | 60 cm   | 100 cm |      |      |  |      |  |  |   |       |       |       |
|   |       |       |       |   |        |      |      |   |      |  |  |   |       |       |       |
|   |       |       |       | 7 mm  |        |      |      |  |      |  |  | 13 mm   | 17 mm | 19 mm | 24 mm |
|  |       |       |       |  |        |      |      |  |      |  |  |  |       |       |       |
| 13 mm   | 17 mm | 19 mm | 24 mm | 4 mm  | 5 mm   | 6 mm | 8 mm | T40  |      |  |  | T45   |       |       |       |
|  |       |       |       |  |        |      |      |  |      |  |  |   |       |       |       |
|   |       |       |       |   |        |      |      |  |      |  |  |   |       |       |       |

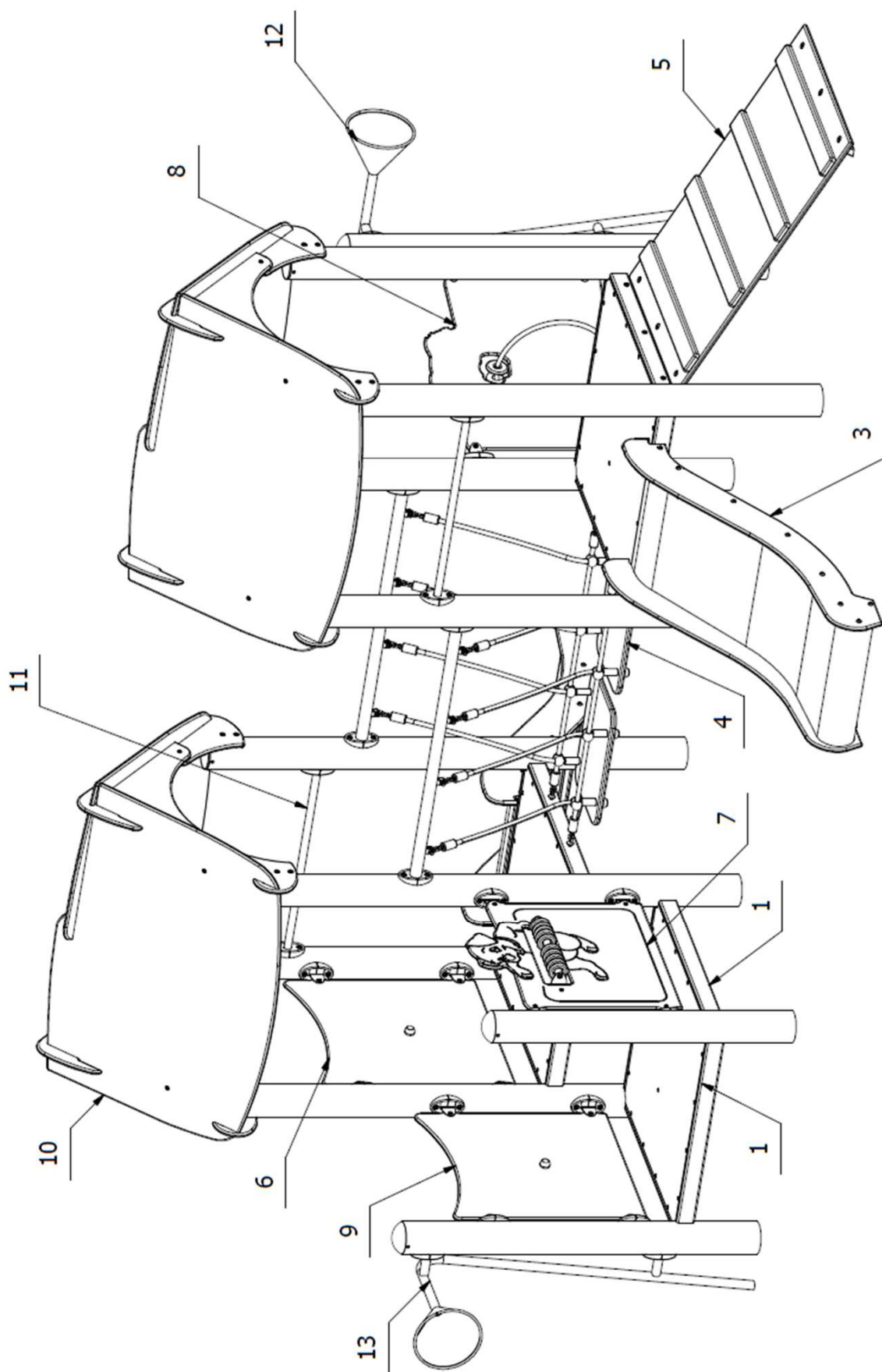

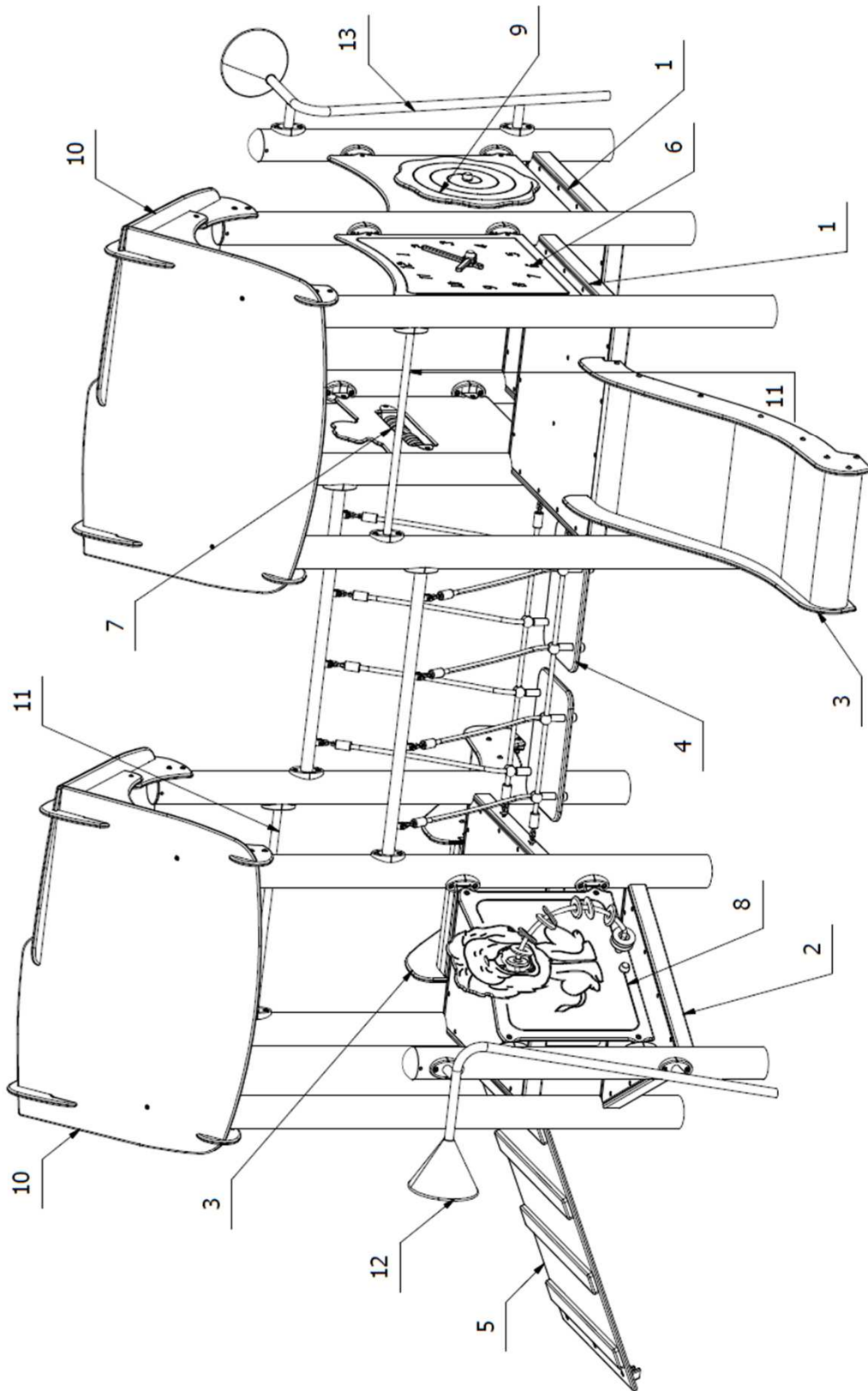

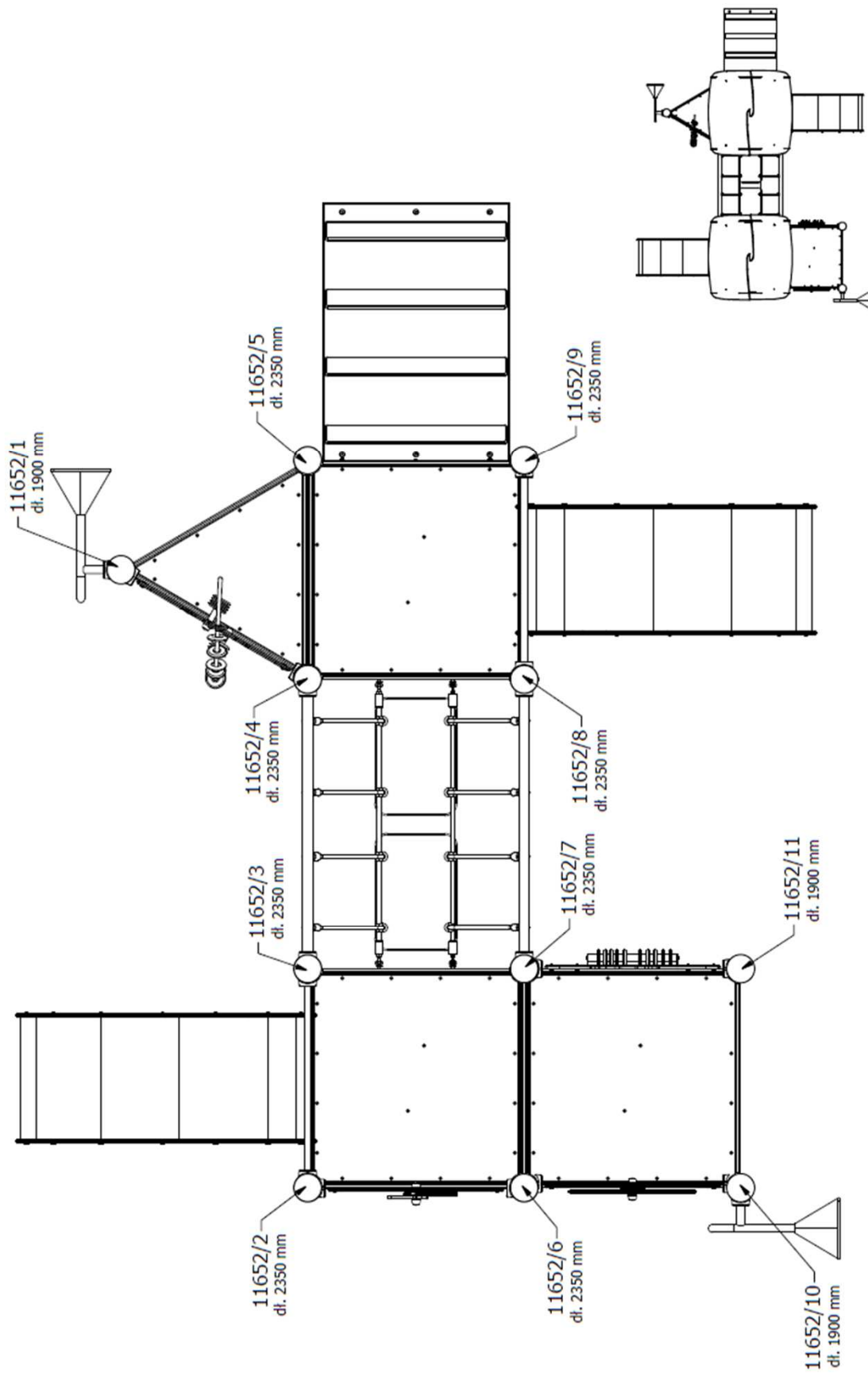

|                     |          |
|---------------------|----------|
| ISO7380_2_M8x16_A2  | 8        |
| Drawing/Norm number | Quantity |

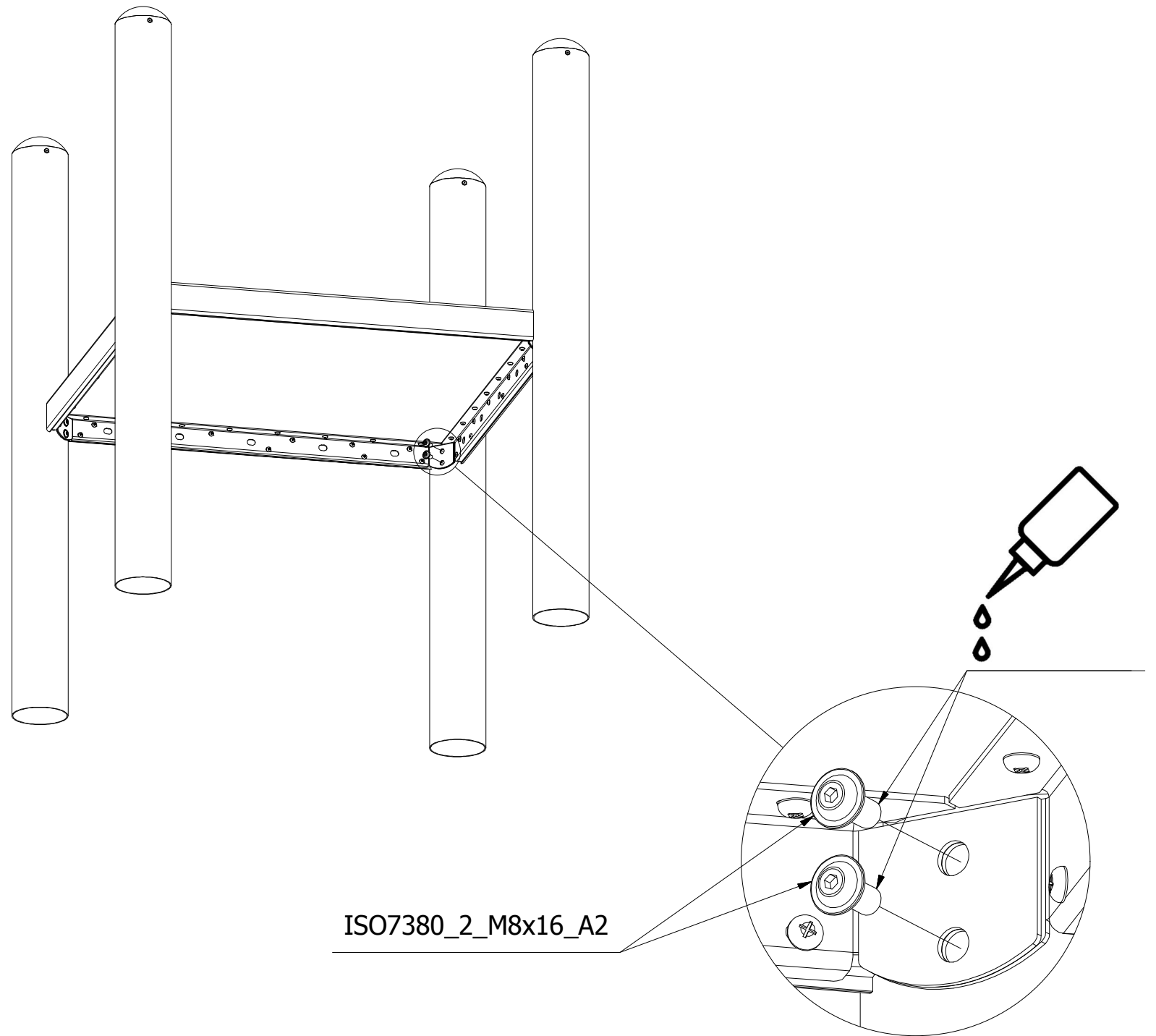
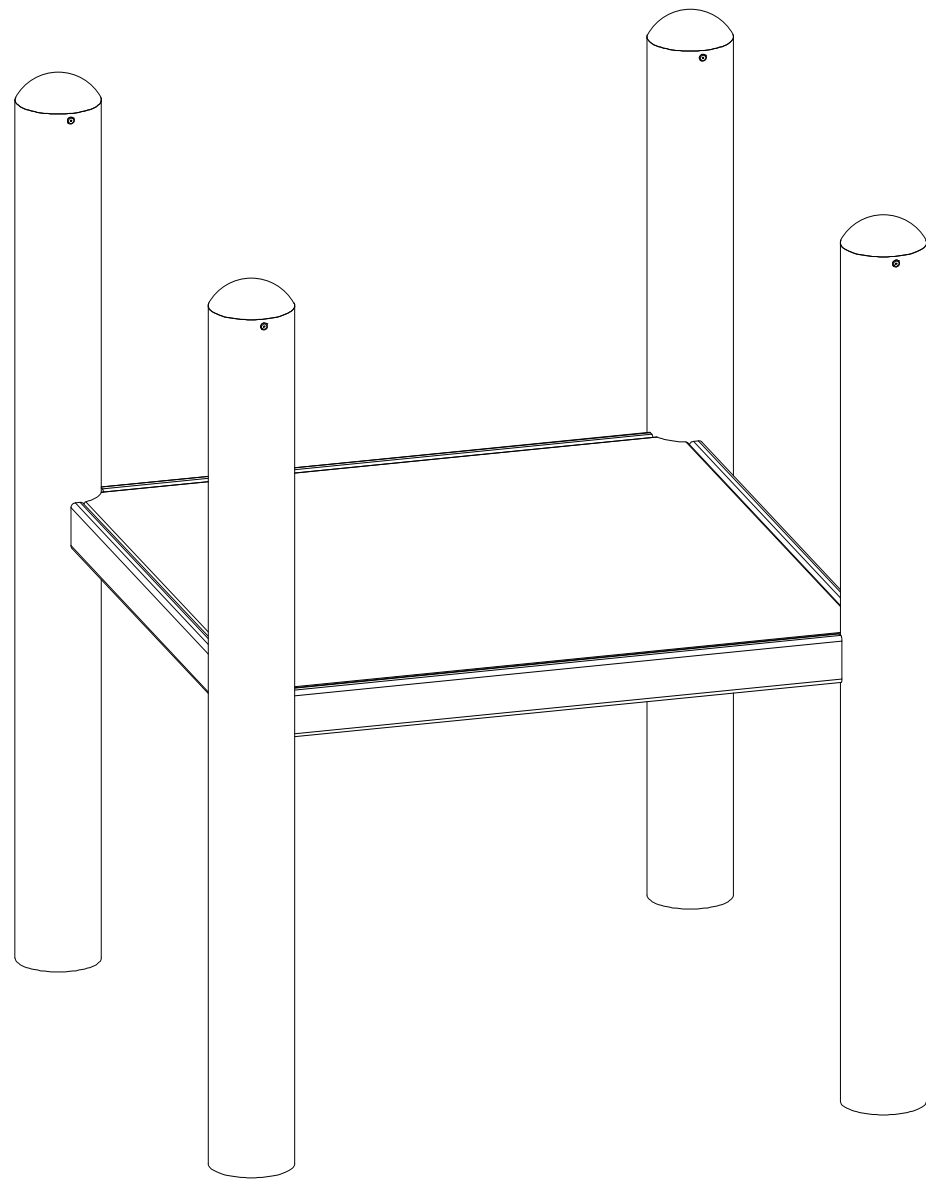

ISO7380\_2\_M8x16\_A2

|                     |          |
|---------------------|----------|
| ISO7380_2_M8x16_A2  | 6        |
| Drawing/Norm number | Quantity |

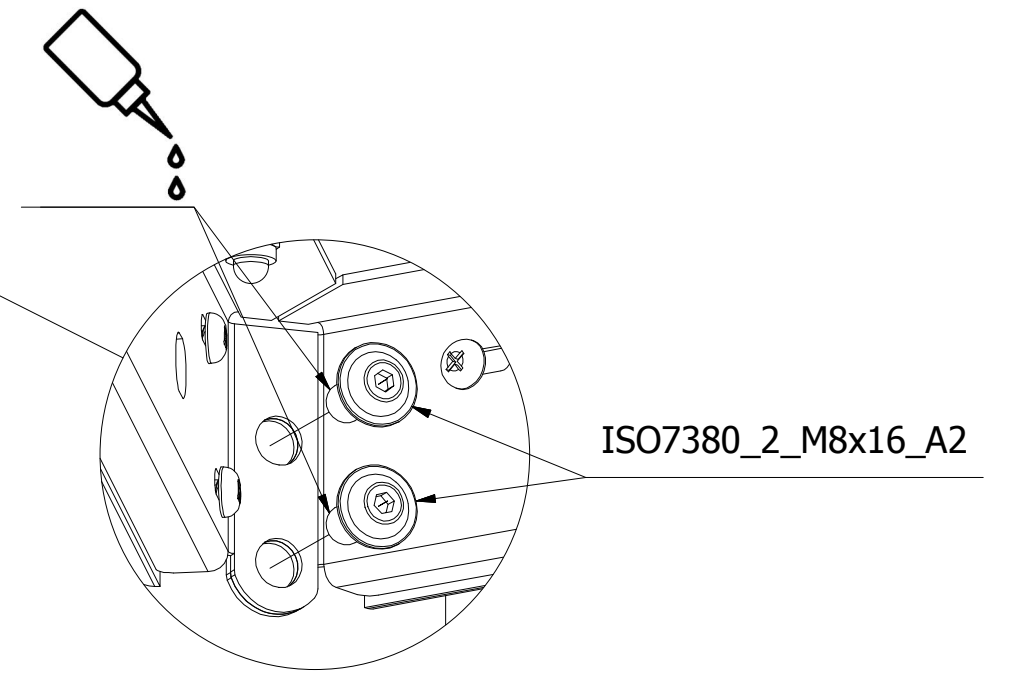
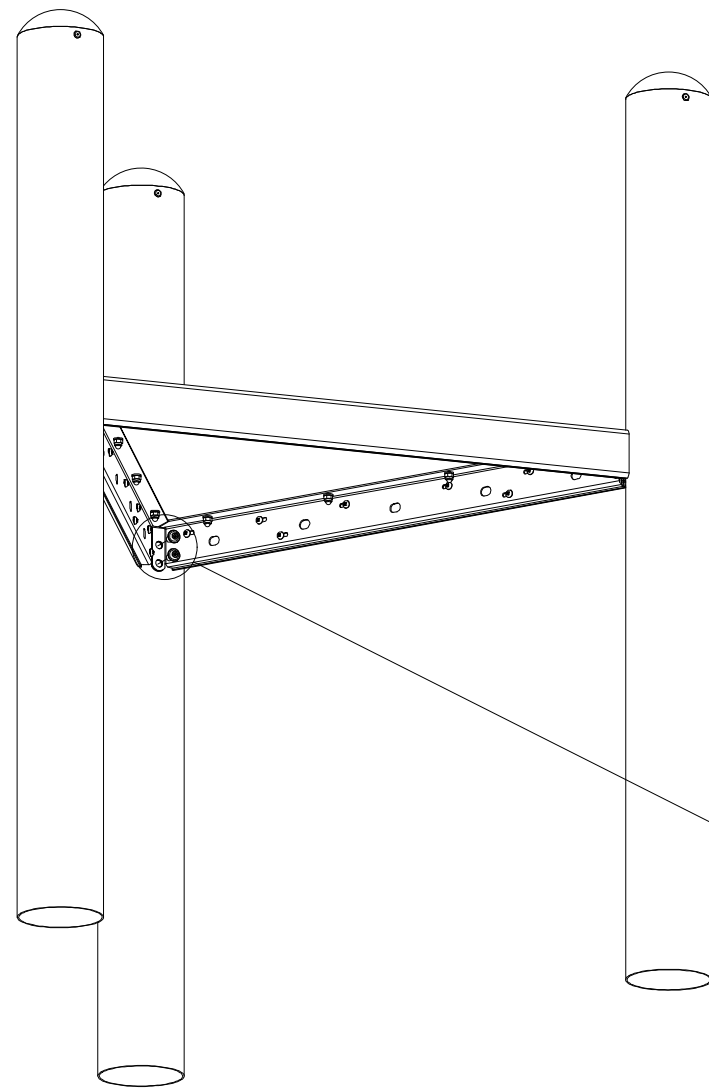
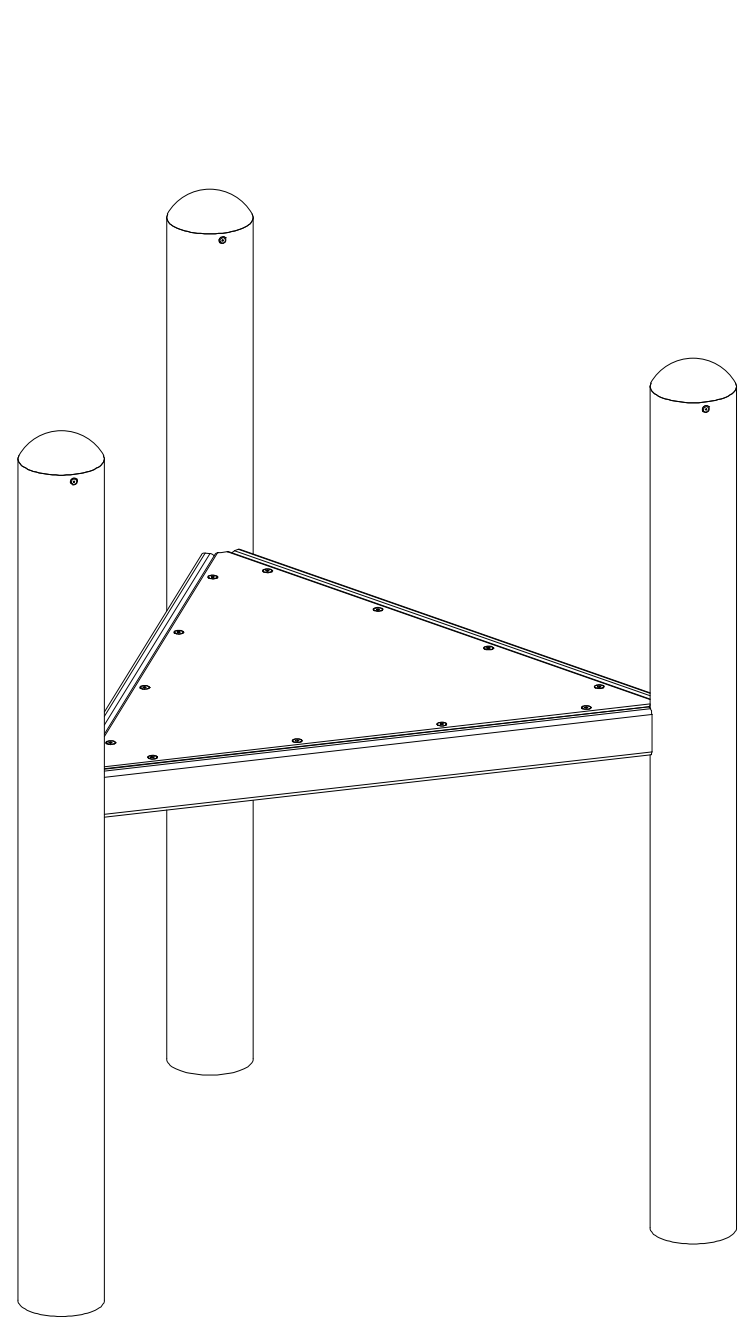

|                     |          |
|---------------------|----------|
| DIN986_M8_A2        | 2        |
| ISO7089_8_A2        | 2        |
| ISO7380_2_M8x40_A2  | 2        |
| Drawing/Norm number | Quantity |

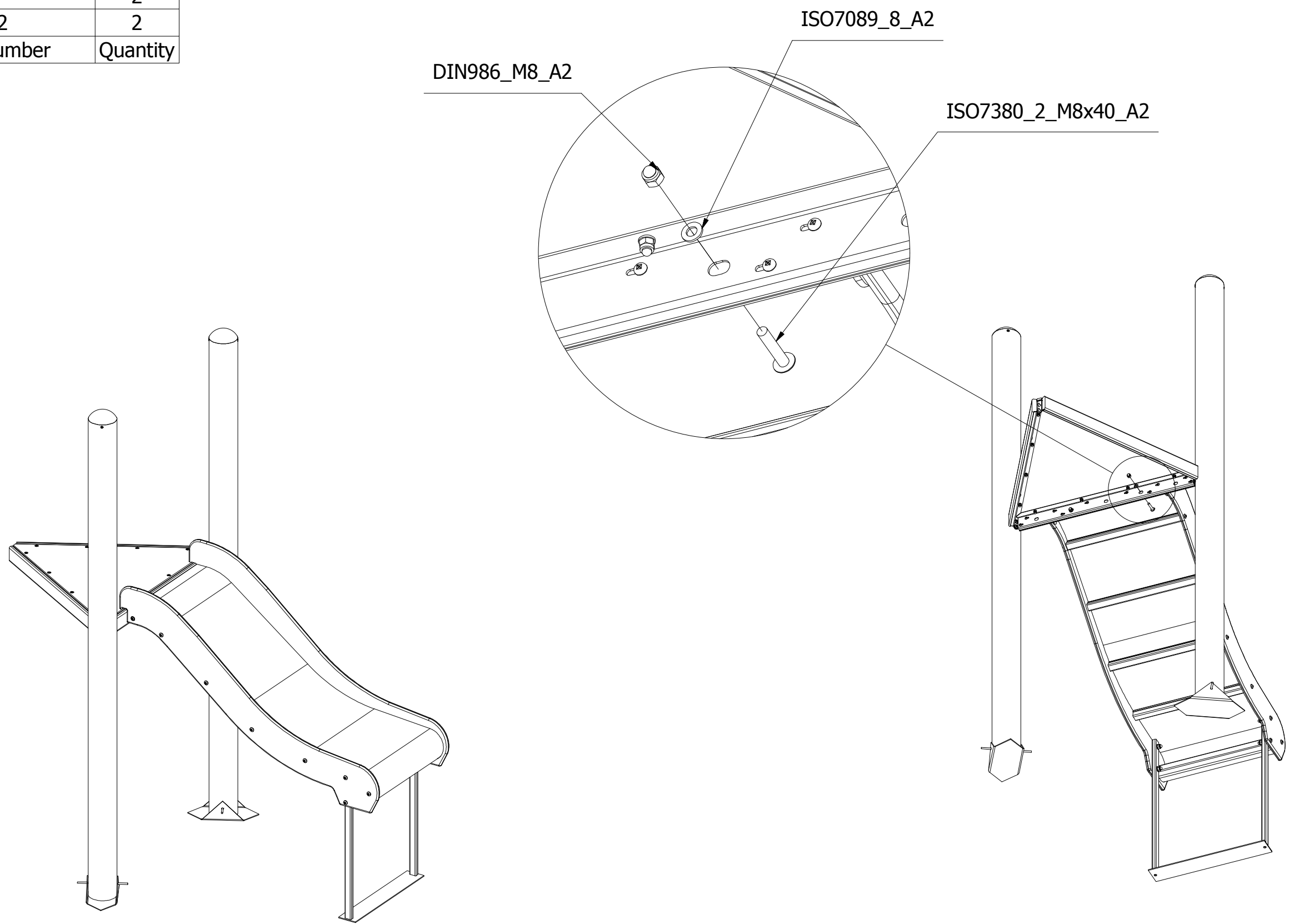

|                     |          |
|---------------------|----------|
| ISO7089_10_A2       | 4        |
| DIN986_M10_A2       | 4        |
| ISO7089_8_A2        | 8        |
| DIN986_M8_A2        | 8        |
| 8919_001            | 8        |
| ISO7380_2_M8x30_A2  | 16       |
| Drawing/Norm number | Quantity |

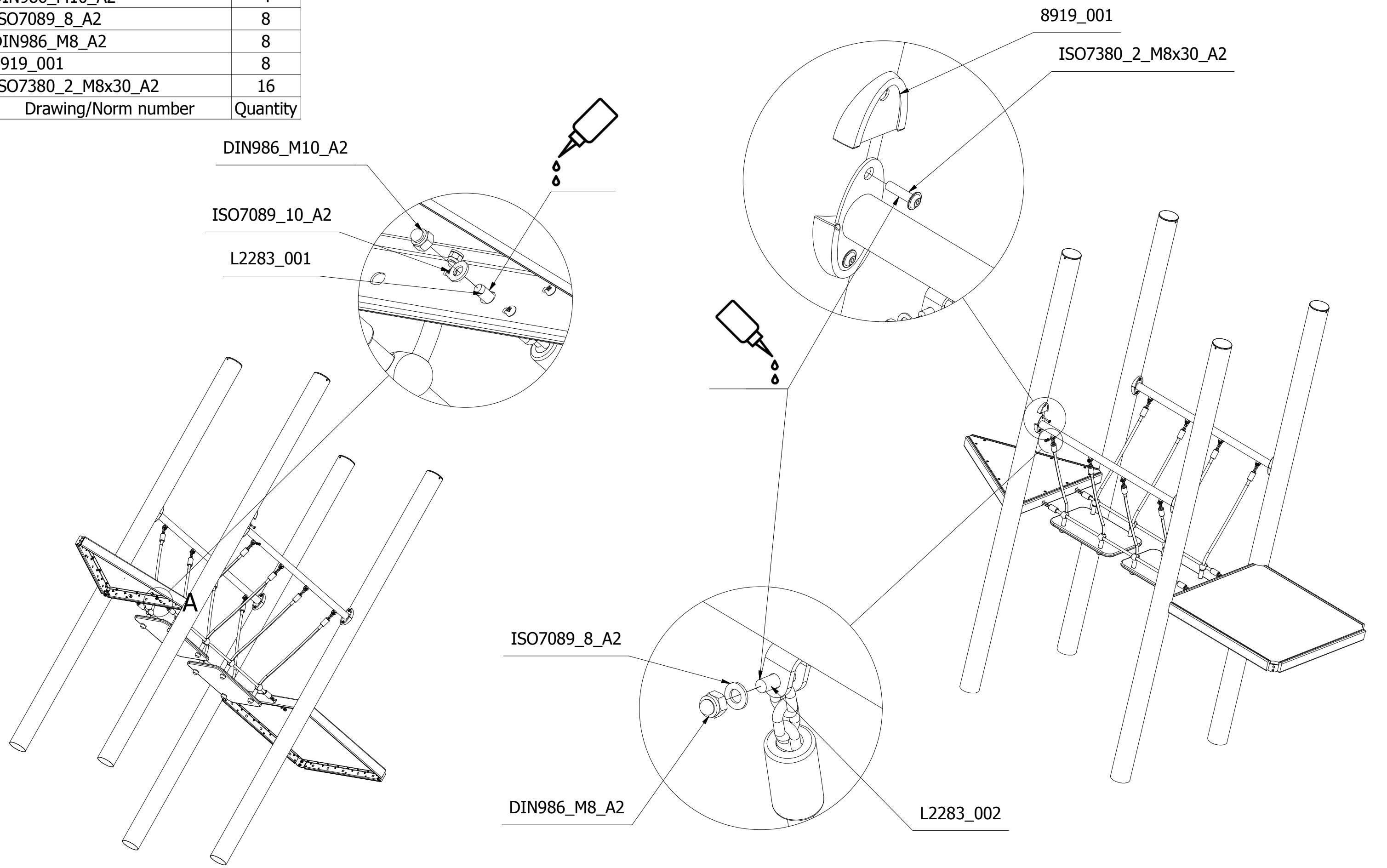

Cat. no.  
**2283\_RM**

|                     |          |
|---------------------|----------|
| DIN986_M8_A2        | 3        |
| ISO7089_8_A2        | 3        |
| ISO7380_2_M8x35_A2  | 3        |
| Drawing/Norm number | Quantity |

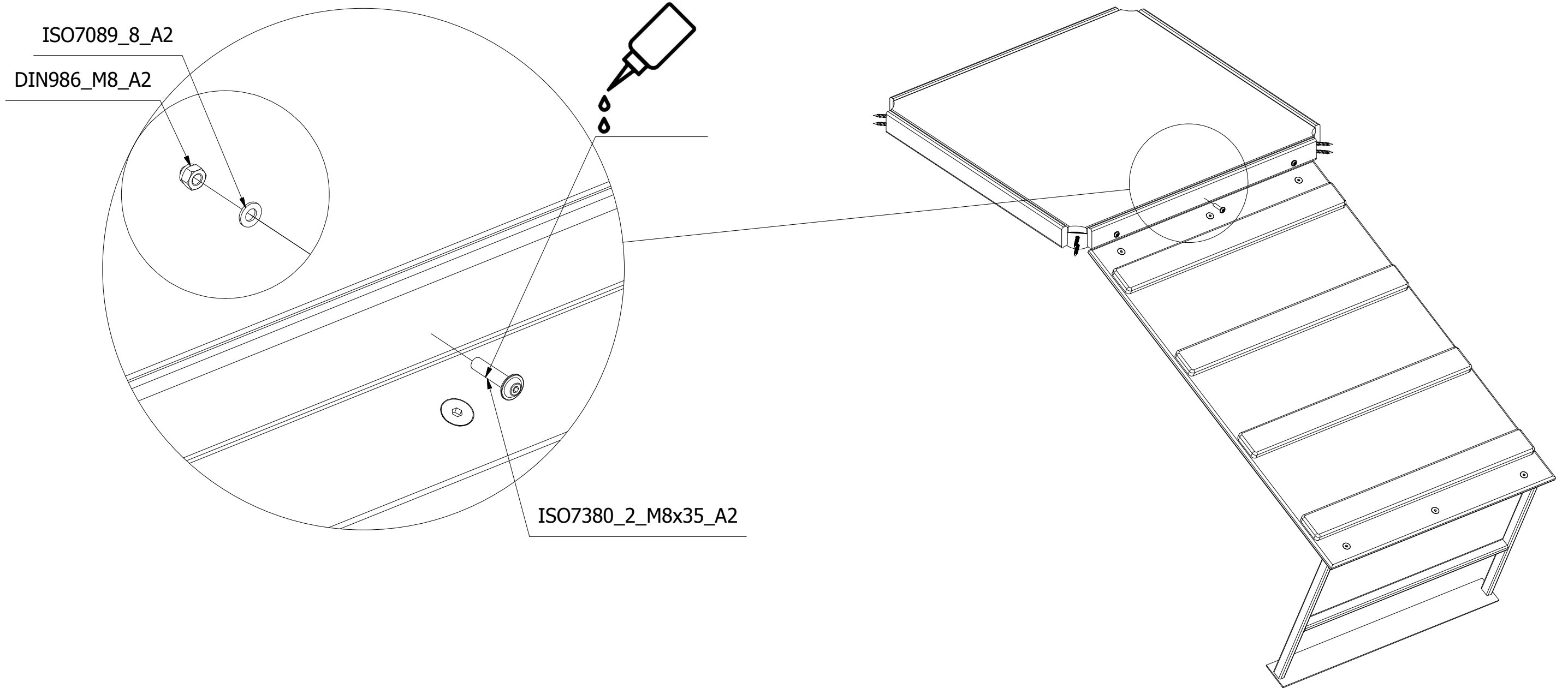

|                     |          |
|---------------------|----------|
| ISO7380_2_M8x16_A2  | 8        |
| B_8801_041          | 4        |
| 8919_001            | 8        |
| ISO7380_2_M6x10_A2  | 4        |
| 8902_007_A2         | 4        |
| Drawing/Norm number | Quantity |

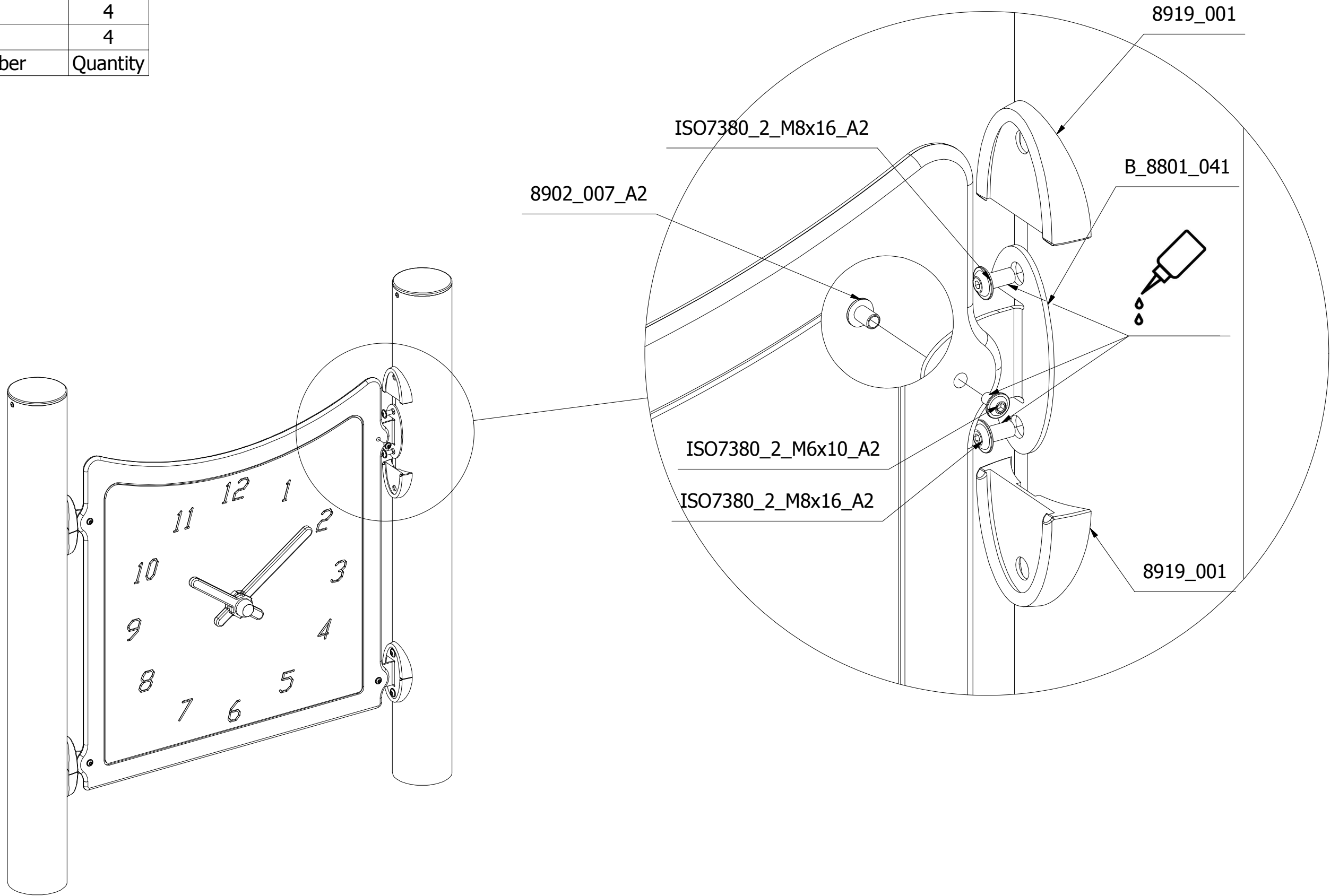

|                     |          |
|---------------------|----------|
| B_8801_041          | 4        |
| ISO7380_2_M8x16_A2  | 8        |
| 8919_001            | 8        |
| 8902_007_A2         | 4        |
| ISO7380_2_M6x10_A2  | 4        |
| Drawing/Norm number | Quantity |

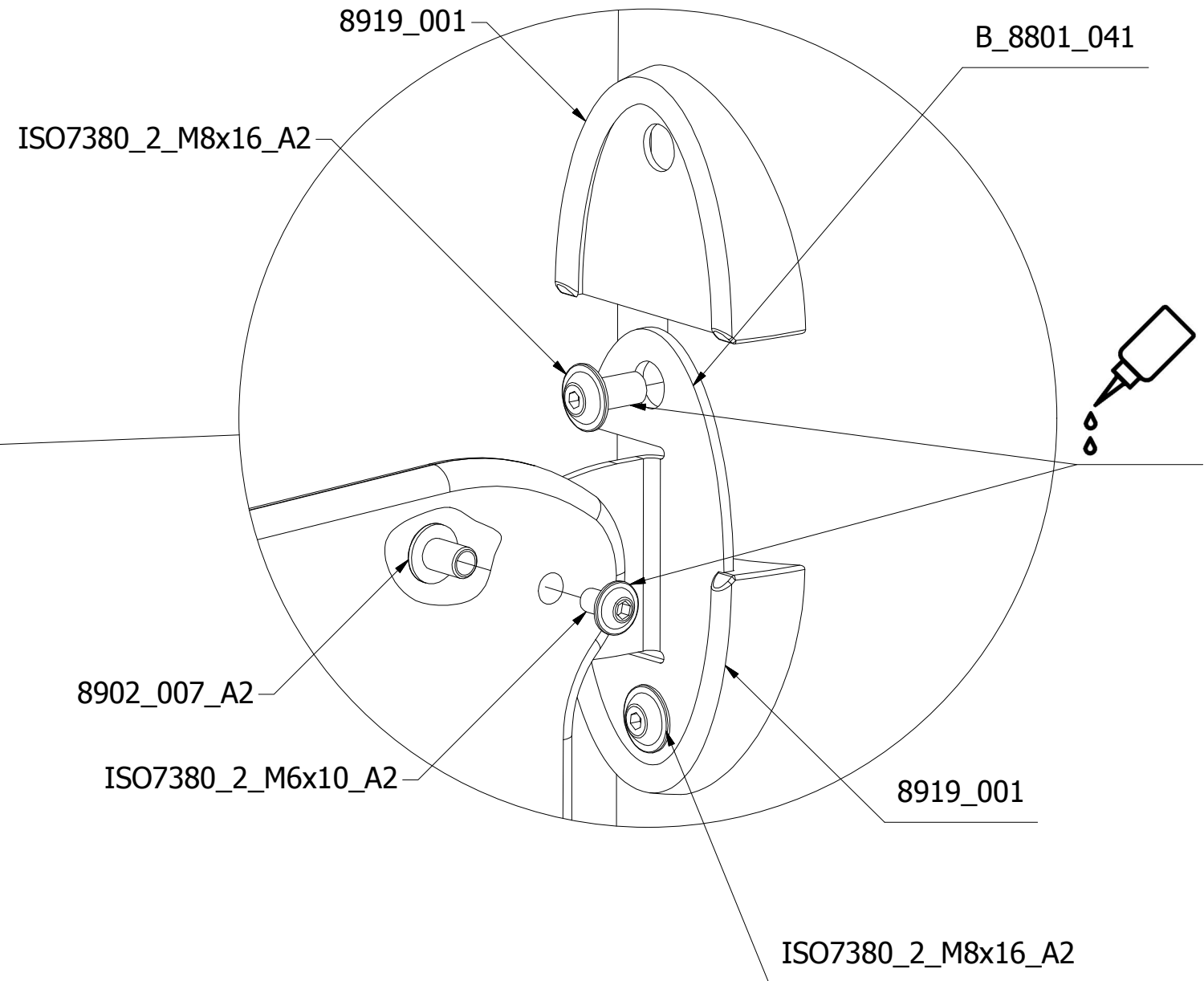
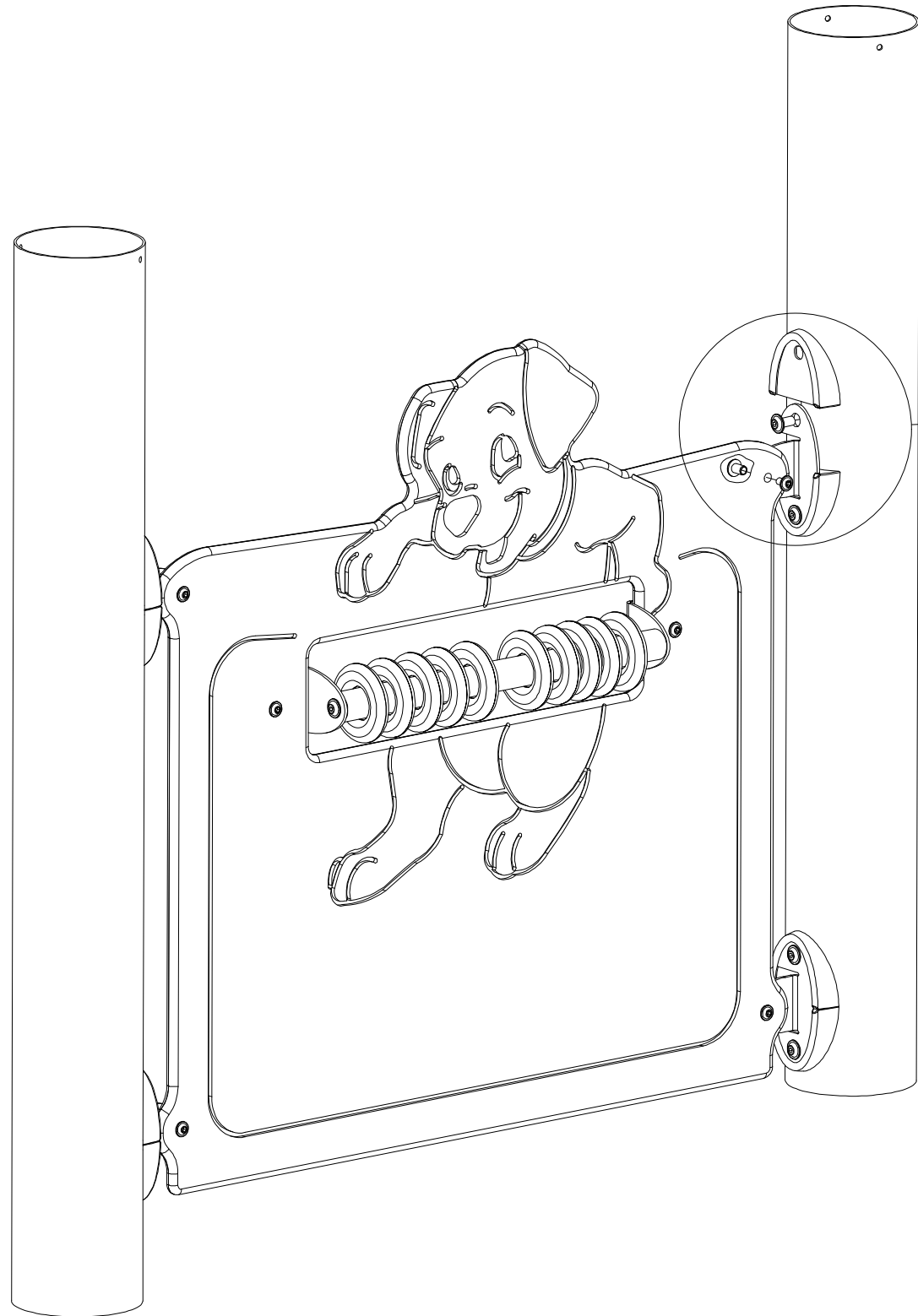

|                     |          |
|---------------------|----------|
| ISO7380_2_M8x16_A2  | 8        |
| 8919_001            | 8        |
| 8902_007_A2         | 4        |
| B_8801_041          | 4        |
| ISO7380_2_M6x10_A2  | 4        |
| Drawing/Norm number | Quantity |

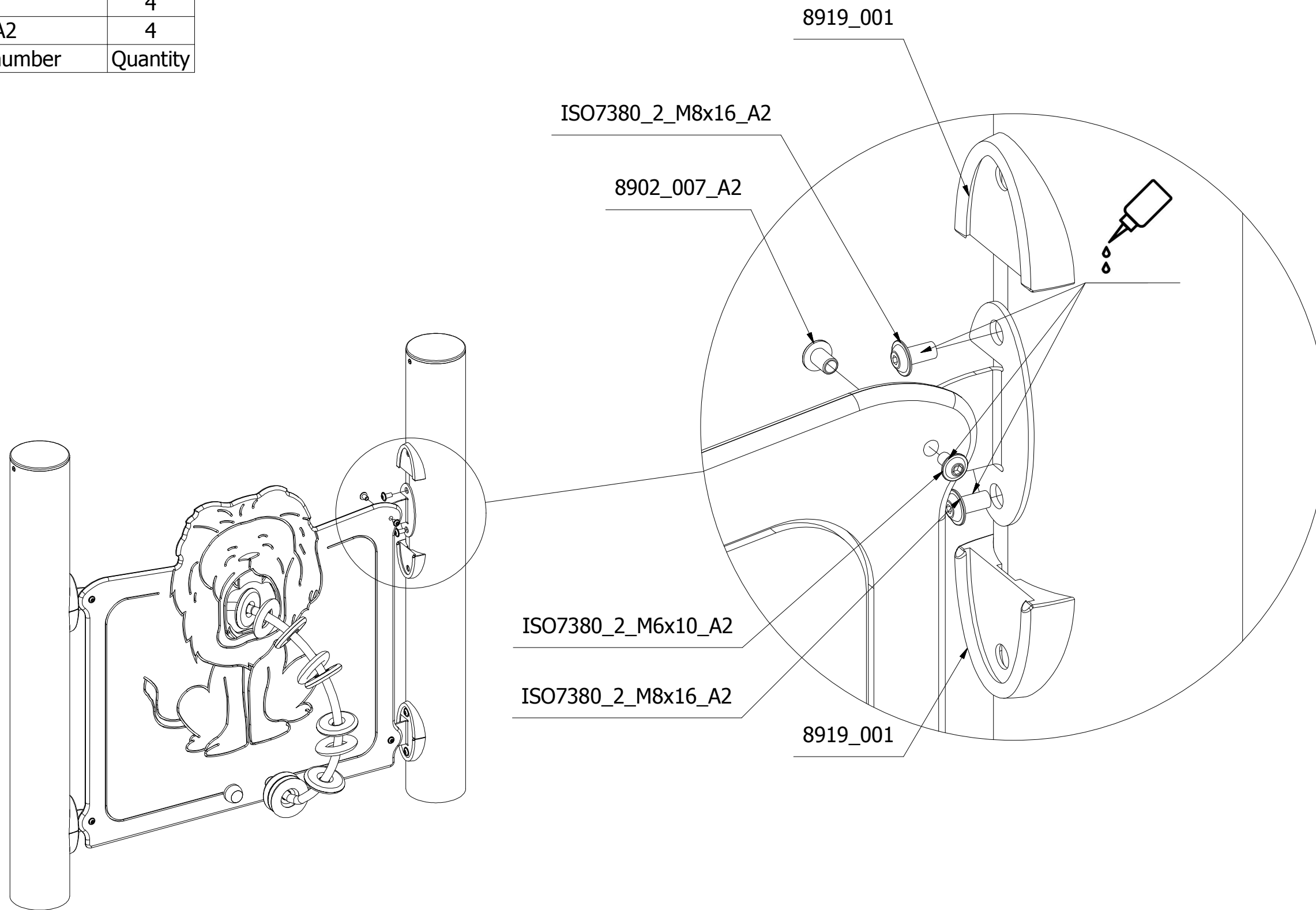

|                     |          |
|---------------------|----------|
| B_8801_041          | 4        |
| ISO7380_2_M8x16_A2  | 8        |
| ISO7380_2_M6x12_A2  | 4        |
| 8902_007_A2         | 4        |
| 8919_001            | 8        |
| Drawing/Norm number | Quantity |

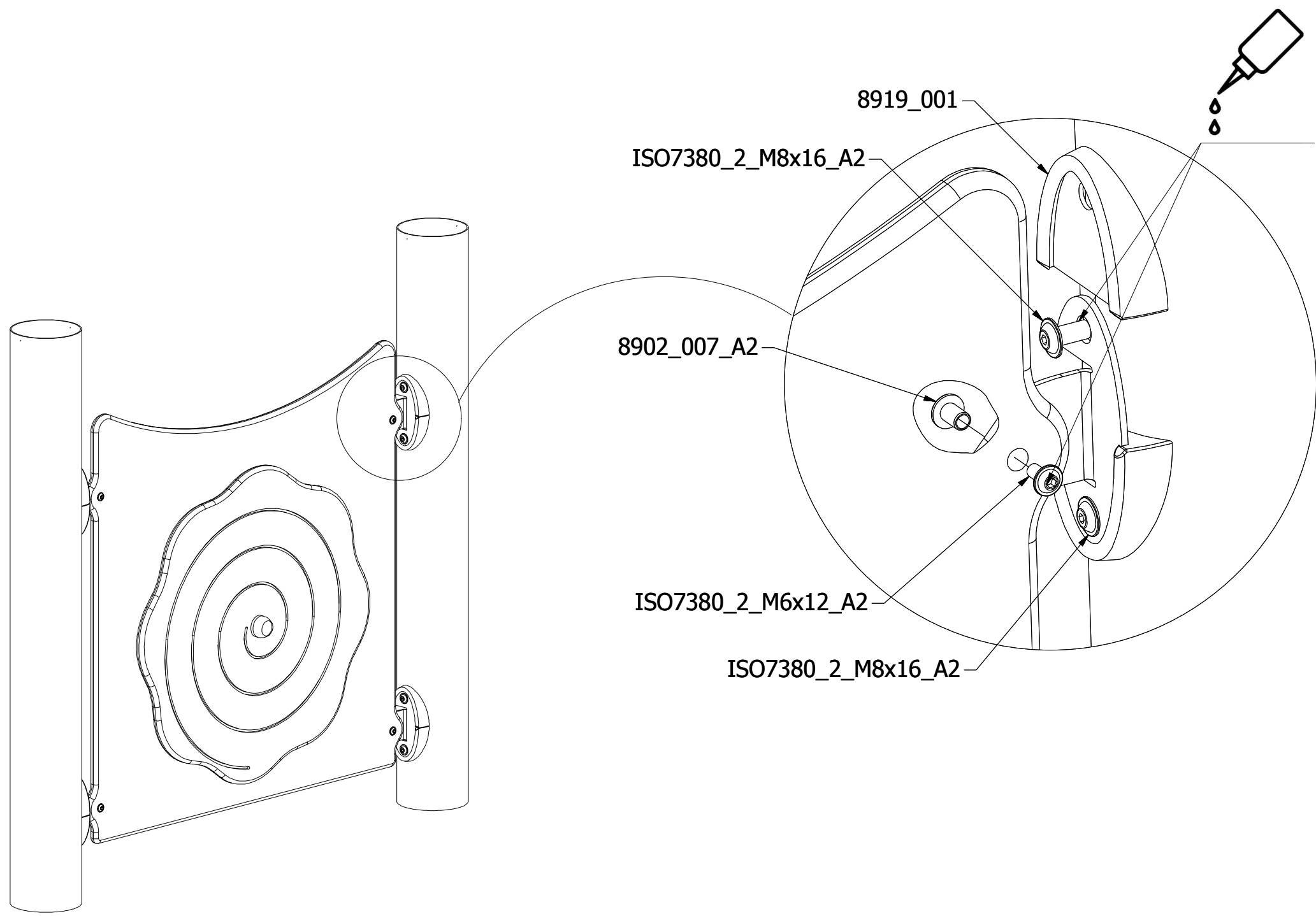

|                     |          |
|---------------------|----------|
| ISO7380_2_M6x12_A2  | 4        |
| ISO7380_2_M6x25_A2  | 6        |
| 8902_007_A2         | 10       |
| B_8801_038_A2       | 4        |
| 8905_001_8x60_A2    | 9        |
| Drawing/Norm number | Quantity |

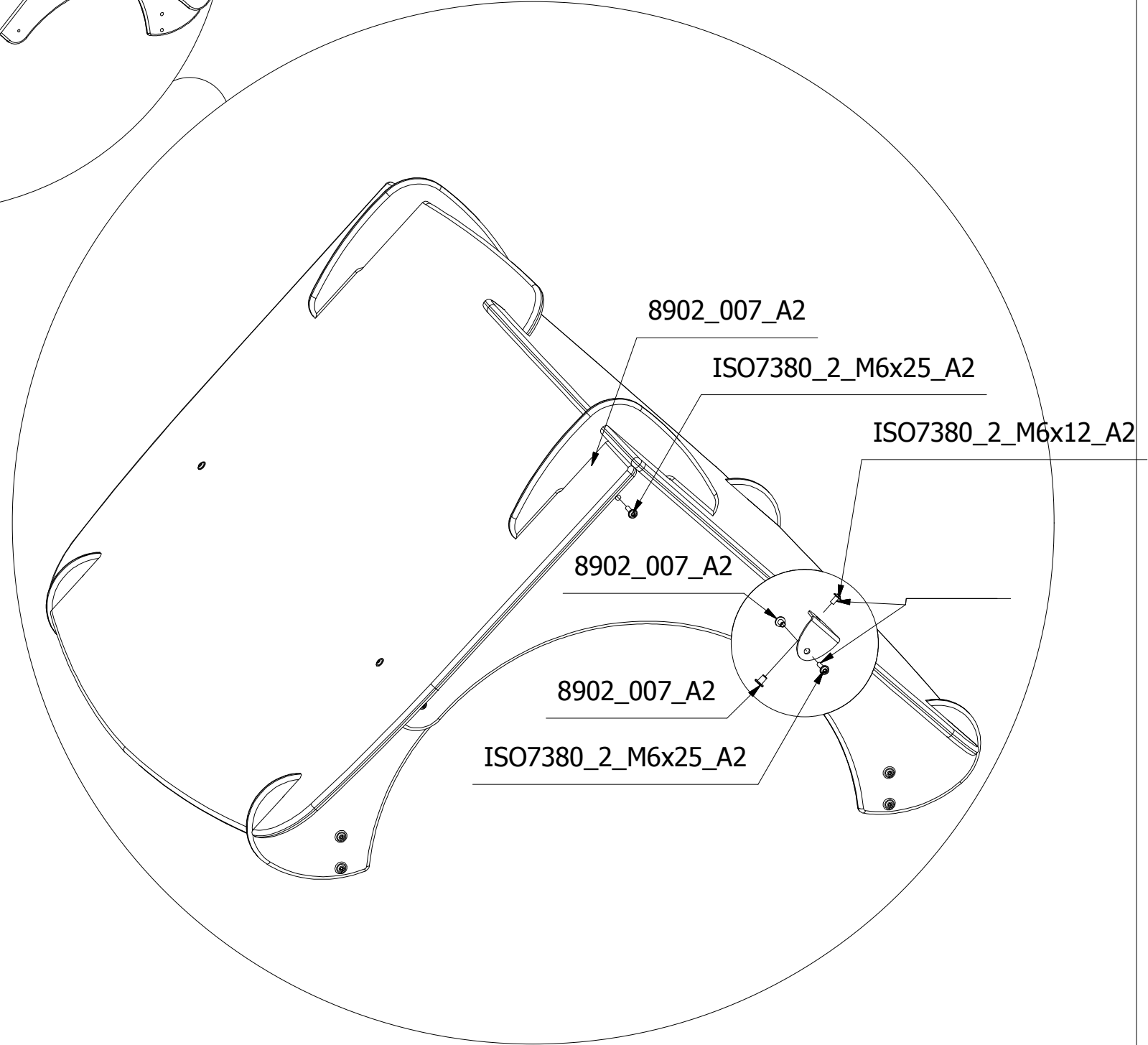
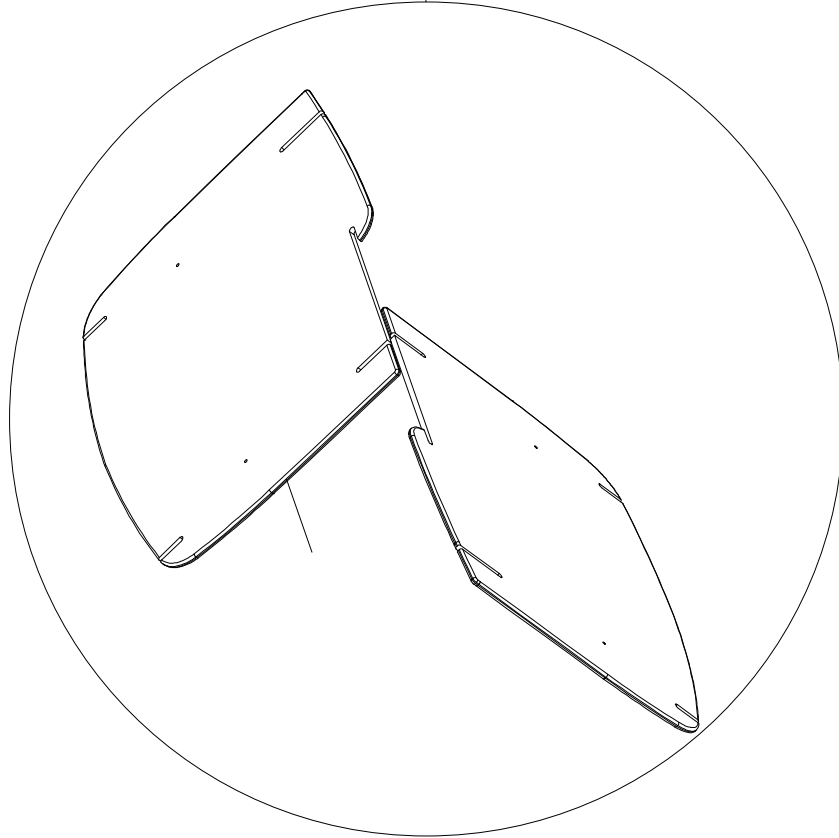
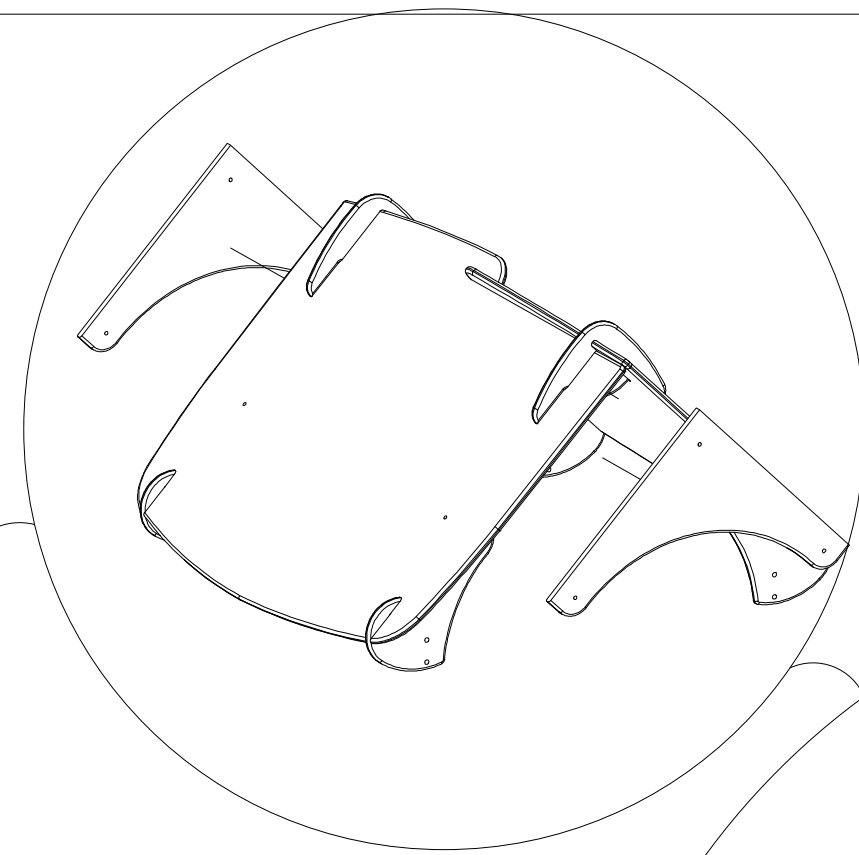
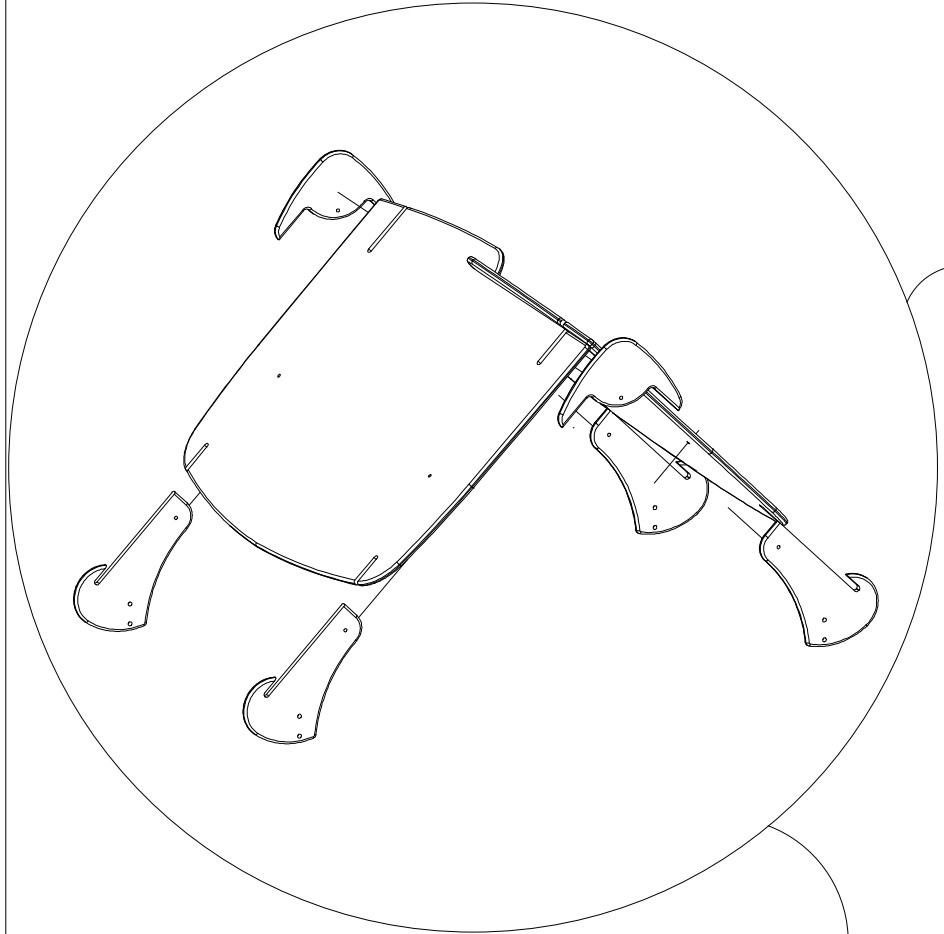

|                     |          |
|---------------------|----------|
| ISO7380_2_M8x25_A2  | 8        |
| Drawing/Norm number | Quantity |

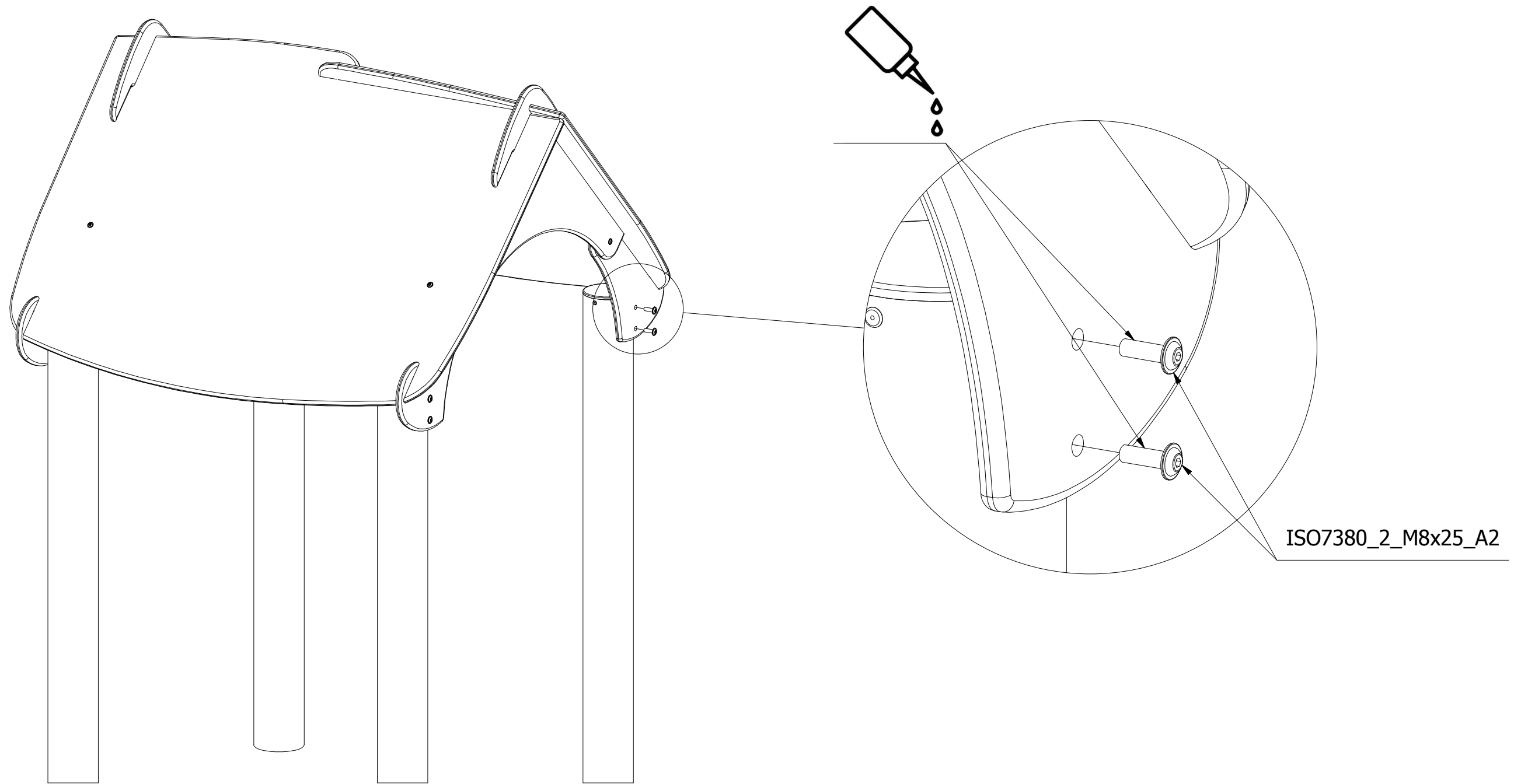

|                     |          |
|---------------------|----------|
| ISO7380_2_M8x16_A2  | 4        |
| 8919_001            | 4        |
| Drawing/Norm number | Quantity |

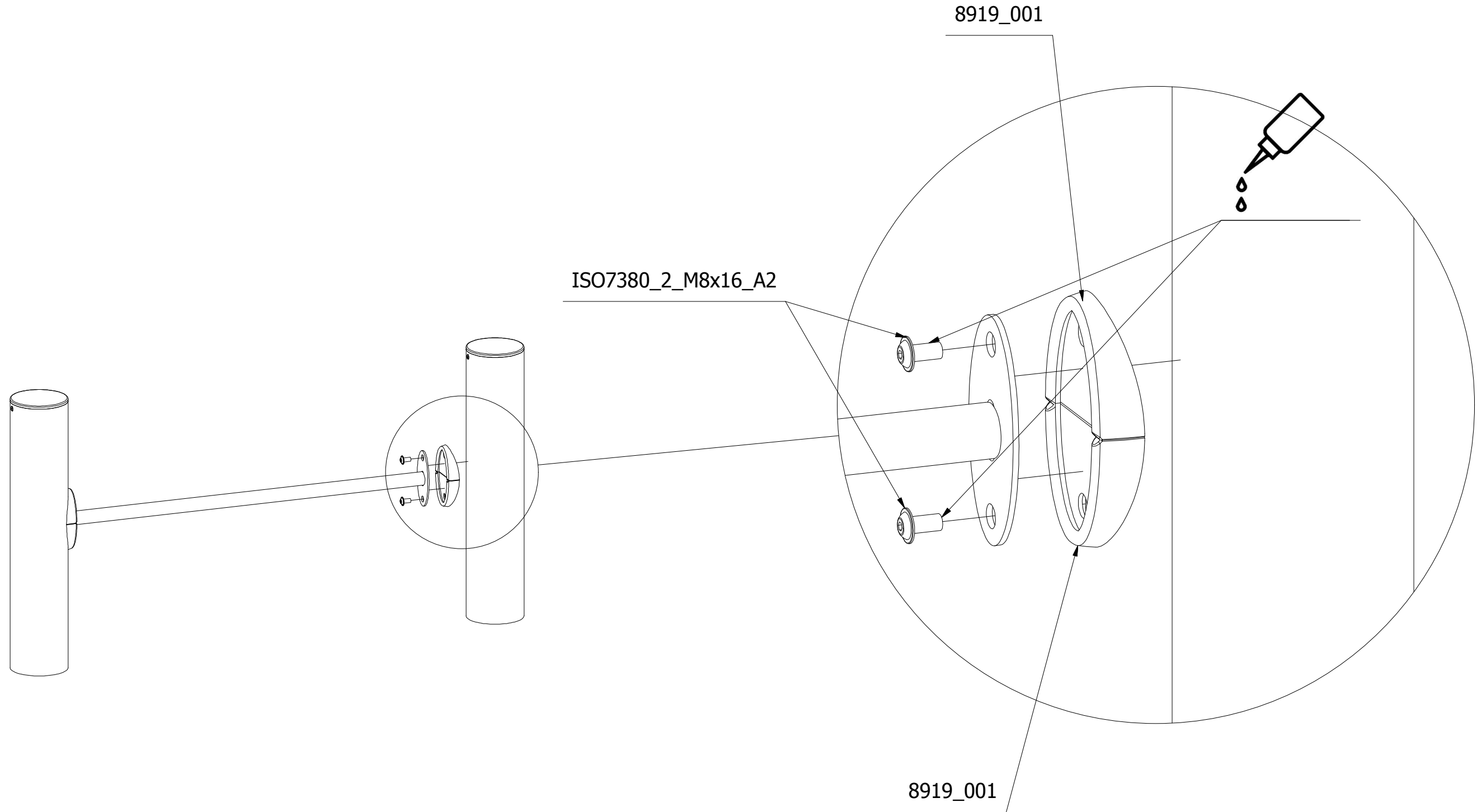

|                     |          |
|---------------------|----------|
| 8953_007            | 1        |
| ISO7380_2_M8x16_A2  | 4        |
| 8919_001            | 4        |
| Drawing/Norm number | Quantity |

